

7 012-255-... 1962 782  
2-13-65... 2-17-65...  
0-17-65... 2-7-65...  
(2-17-65...)

# TECHNIQUES FOR INFRARED SURVEY OF SEA TEMPERATURE

Marine Biological Laboratory  
LIBRARY  
MAR 8 1965  
WOODS HOLE, MASS.



UNITED STATES DEPARTMENT OF THE INTERIOR  
FISH AND WILDLIFE SERVICE  
BUREAU OF SPORT FISHERIES AND WILDLIFE  
Bureau Circular No. 202

The United States Department of the Interior, created in 1849, is concerned with management, conservation, and development of the Nation's water, wildlife, fish, mineral, forest, and park and recreational resources. It has major responsibilities also for Indian and Territorial affairs.

As America's principal conservation agency, the Department works to assure that nonrenewable resources are developed and used wisely, that park and recreational resources are conserved for the future, and that renewable resources make their full contribution to the progress, prosperity, and security of the United States, now and in the future.

UNITED STATES DEPARTMENT OF THE INTERIOR, STEWART L. UDALL, SECRETARY

Frank P. Briggs, Assistant Secretary for Fish and Wildlife

Fish and Wildlife Service, Clarence F. Pautzke, Commissioner

Bureau of Sport Fisheries and Wildlife, John S. Gottschalk, Director

## TECHNIQUES FOR INFRARED SURVEY OF SEA TEMPERATURE

Report of a workshop held  
at the U. S. Department of the Interior, Washington, D. C.

April 27 and 28, 1964

John Clark, Chairman  
Bureau of Sport Fisheries and Wildlife  
Sandy Hook Marine Laboratory  
Highlands, New Jersey

Sponsored by  
The Geophysics Branch, Office of Naval Research  
in cooperation with  
The Committee for Scientific Exploration of the Atlantic Shelf



Bureau Circular No. 202 - November 1964  
Issued at the Sandy Hook Marine Laboratory



## CONTENTS

Page

### PART 1 — REPORT OF WORKSHOP

Introduction . . . . .	1
Plan of workshop . . . . .	3
Registered participants . . . . .	5
Presentation of papers . . . . .	8
Discussion of basic questions . . . . .	17
Continued IRT survey and second workshop . . . . .	23

### PART 2 — CONTRIBUTIONS

Accuracy of Airborne Infrared Thermometry, by John L. Frank . . . . .	25
Airborne Infrared Oceanic Mapping, by Paul M. Moser . . . . .	37
Airborne Radiation Thermometer on the Pacific Coast of Canada, by J. P. Tully . . . . .	41
Calibration and Field Test of IRT, by Takashi Ichiye and Noel B. Plutchak . . . . .	44
Comments on the Validity of Sea Surface Temperatures as Measured With the Barnes Infrared Thermometer, by Robert A. Ragotzkie . . . . .	53
Comments Relative to Infrared Radiation Thermometer Workshop, by John W. Reintjes . . . . .	56
Infrared Radiation Thermometer — an Evaluation by Robert C. Barnes . . . . .	60
Infrared Survey Technique as a Means of Determining Mississippi River Discharge Patterns and Surface Flow Along the Northern Gulf Coast, by K. L. Drennan . . . . .	69
Observations of Some Physical Factors Affecting the Use of an Airborne Radiometer, by James L. Squire, Jr. . . . .	76
Slithering Isotherms and Thermal Fronts on the Ocean Surface, by G. C. Ewing . . . . .	92
Some Factors Influencing the Skin-Temperature of the Sea and its Measurement by Infrared Thermometer, by Guy A. Franceschini . . . . .	94
Use of the Barnes Model 14-320 Airborne Radiation Thermometer in Aerial Surveys Over the North Atlantic, by Robert A. Peloquin, John C. Wilkerson and George L. Hanssen . . . . .	112
Use of the Infrared Thermometer in Routine Coastal Survey — a Summary, by John Clark and Richard B. Stone . . . . .	134



PART 1 -- REPORT OF WORKSHOP





## INTRODUCTION

The Workshop on Techniques for Infrared Survey of Sea Temperature was held to evaluate the state of the art of measuring sea surface temperatures with infrared detecting equipment. The simplest form of detector, the infrared thermometer (IRT), is calibrated to give direct read-out of surface temperature. Because this instrument is now a stock item and relatively inexpensive, there has been a rapid increase in its use in oceanographic and limnological survey. An opportunity to exchange information on techniques and interpretation of readings appeared to be needed because there was little information in print with which to evaluate the usefulness of IRT survey.

Civilian and military interests in IRT sea surface temperature mapping coincide in the area of large-scale survey. Since thermal mapping of the surface can be accomplished with airborne IRT in one-tenth or one-twentieth of the time required with surface craft, it has become possible to conduct, economically, periodic temperature surveys of large areas of oceans or lakes. The need for this kind of information in marine ecology was set forth by L. A. Walford in the following statement to the Committee for Scientific Exploration of the Atlantic Shelf (SEAS Committee) in 1962:

"Marine zoologists, fishery biologists, botanists, geologists, physical oceanographers, and geographers working on the Atlantic Continental Shelf are concerned with problems of large dimensions in space and time. Many, if not most, of the subjects of their studies extend for hundreds of miles and undergo regular seasonal changes, random fluctuations, and, in many instances, long-range oscillations. Research on such large-scale phenomena depends upon collections of data taken simultaneously over large enough areas to bring out significant details of entire distributions and at frequent intervals over a long enough period of time to cover a considerable range of variation. All of the marine sciences collectively called oceanography are interrelated. Understanding of any one of them is furthered by information about all the others.

"This information must be collected systematically and synoptically about several elements of marine environment, and all disciplines have certain needs in common. The data in greatest demand relate to the regimes of temperature and chemical composition of the water, direction, and rate of movements of currents, distribution of sediments, and distribution of species of animals and plants.

"Scientists in research institutions all along the Atlantic coast are ready to use such data as have been described and would refer to them continually for many purposes if they were available. But the fact is they are not available, and for the simple reason that they have never been collected. It is true that several surveys have been made of segments of the coast, but the results can not be fitted together to construct a total picture of any subject relating to the shelf environment for any one time. The best one can do is fit together bits and pieces collected in different times of different years by different people using different methods. But the results are of little use for seeking fundamental principles."

Systematic IRT temperature surveys were initiated in 1962 by the U. S. Bureau of Sport Fisheries and Wildlife on both the Atlantic and the Pacific coasts. These studies are incorporated into a new Federal program of research on migratory salt-water sport fishes concentrated on understanding how environmental parameters influence distribution and well-being of migratory coastal species.

Under the encouragement of the SEAS Committee an expanded cooperative program of survey is being established for the Atlantic coast. Thermal mapping with IRT on a monthly basis is now planned to extend from Cape Cod to Cape Fear and along the northern coast of the Gulf of Mexico in the following sections:

1. Cape Cod, Mass., to Cape Henlopen, Del. - - Sandy Hook Marine Laboratory.
2. Cape Henlopen, Del., to Cape Hatteras, N. C. - - Virginia Institute of Marine Science.
3. Cape Hatteras, N.C., to Cape Fear, N.C. - - Beaufort Biological Laboratory.
4. Northern Gulf of Mexico - - Gulf Coast Marine Laboratory.

The SEAS Committee is considering a plan under which this survey program could be expanded eventually to cover the whole Atlantic coast at frequent intervals, and for records to be forwarded to a central clearinghouse to provide for regular and prompt issuance of coastal thermal maps. With this goal in view the Committee is vitally interested that standards be established for IRT survey methods and reporting systems.

On the Pacific coast, the Tiburon Marine Laboratory monthly survey program includes the following areas:

1. Cape Flattery, Wash., to Cape Lookout, Ore.
2. Point Arena, Calif., to Point Sur, Calif.
3. Point Arguello, Calif., to Punta Salsipuedes in Mexico.

## PLAN OF WORKSHOP

To facilitate the discussions of the workshop and to ensure that usable conclusions should be reached, the discussions were designed to center on the following 10 basic questions:

1. What instruments are available for infrared detection of sea surface temperature from aircraft?
2. What are the limits of instrument accuracy of presently available IRT equipment?
3. What are the important operational problems with infrared thermometers, and what possible solutions are there?
4. What limitations are imposed by variable meteorological conditions, and to what extent can the effect of any of these be predicted and the data corrected?
5. What factors other than meteorological act at the air-sea interface to affect the accuracy of IRT sea-surface temperature determination?
6. In view of the answers to the above questions, what specifically are we measuring when we use the IRT over water?
7. What are the limits of accuracy of data collected with presently available infrared equipment in predicting "microsurface" temperatures, "bucket temperatures," and mixed-layer temperatures?
8. What can be done to standardize the collection, reporting, processing, and storage of IRT data and to expedite its retrieval and dissemination?
9. What are the best uses to which the presently available IRT data can be put?
10. What improvements could be made to reduce sources of error in presently available IRT equipment?

The first part of the workshop consisted in individual presentations of experience with IRT equipment and discussions of resulting data. A brief account of these presentations and a summary of the discussions are given in the section on Presentation of Papers. Complete minutes were not kept because all papers presented are included in Part 2 -- Contributions.

The second part of the workshop consisted in discussions of the 10 basic questions. These discussions and the resulting conclusions are given in the section on Discussion of Basic Questions.

A central working panel of 12 representatives was selected to carry out the principal business of the workshop. In addition to the panel there were 28 observers, many of whom made substantial contributions to the discussions. Mr. John L. Frank of Barnes Engineering Company, Stamford, Conn., was technical advisor to the workshop.

## REGISTERED PARTICIPANTS

### Panel

John R. Clark (Chairman), Sandy Hook Marine Laboratory, Highlands, N. J.

Robert C. Barnes (Recorder), Virginia Institute of Marine Science, Gloucester Point, Va.

Kirby L. Drennan, Gulf Coast Research Laboratory, Ocean Springs, Miss.

Gifford C. Ewing, Scripps Institute of Oceanography, La Jolla, Calif.

Guy A. Franceschini, Texas A & M University, Department of Oceanography and Meteorology, College Station, Tex.

Takashi Ichiye, Lamont Geological Observatory, Palisades, N. Y.

Paul M. Moser, U. S. Naval Air Development Center, Johnsville, Pa.

Robert A. Peloquin, U. S. Naval Oceanographic Office, Washington, D. C.

John W. Reintjes, U. S. Biological Laboratory, Beaufort, N. C.

James L. Squire, Jr., Tiburon Marine Laboratory, Tiburon, Calif.

Richard B. Stone, Sandy Hook Marine Laboratory, Highlands, N. J.

John P. Tully, Pacific Oceanographic Group, Fisheries Research Board of Canada, Nanaimo, British Columbia, Canada

### Technical Advisor

John L. Frank, Barnes Engineering Co., Stamford, Conn.

### Observers

G. L. Athey, U. S. Naval Oceanographic Office, Washington, D. C.

J. F. Carr, U. S. Bureau of Commercial Fisheries, Ann Arbor, Mich.

Floyd C. Elder, Department of Meteorology and Oceanography, University of Michigan, Ann Arbor, Mich.



George L. Hanssen, U. S. Naval Oceanographic Office, Washington, D. C.

T. E. Heindsmann, Technical Staff, Aero Space, Boeing Co., Seattle, Wash.

M. Keller, Division of Photogrammetry, U. S. Coast and Geodetic Survey, Washington, D. C.

George M. Lucich, U. S. Bureau of Commercial Fisheries, Navy Yard Annex, Washington, D. C.

Harry F. Maier, Barnes Engineering Co., Stamford, Conn.

S. O. Marcus, National Oceanographic Data Center, Washington, D. C.

D. P. Martineau, Office of Naval Research, Washington, D. C.

Arthur E. Maxwell, Office of Naval Research, Washington, D. C.

Thomas R. Mee, Meteorological Research, Inc., Altadena, Calif.

Carl D. Miller, Infrared Lab., Institute of Science and Technology, University of Michigan, Ann Arbor, Mich.

James W. McGary, U. S. Coast Guard, Navy Yard Annex, Washington, D. C.

Hugh J. McLellan, Office of Naval Research, Washington, D. C.

Jerome Namias, U. S. Weather Bureau, Washington, D. C.

W. Henry Odum, National Oceanographic Data Center, Washington, D. C.

Albert H. Oshiver, U. S. Coast and Geodetic Survey, Washington, D. C.

Noel B. Plutchak, Lamont Geological Observatory, Palisades, N. Y.

Robert L. Plye, National Weather Satellite Center, Washington, D. C.

Robert A. Ragotzkie, Department of Meteorology, University of Wisconsin, Madison, Wis.

John J. Russell, U. S. Naval Oceanographic Office, Washington, D. C.

John G. Sanderson, U. S. Naval Research Laboratory, Washington, D. C.

Bernard E. Skud, U. S. Bureau of Commercial Fisheries, Boothbay Harbor, Me.

Albert H. Swartz, U. S. Bureau of Sport Fisheries and Wildlife, Washington, D. C.

Wellington Waters, National Oceanographic Data Center, Washington, D. C.

Hans J. Wetzstein, Institute of Naval Studies, Cambridge, Mass.

John C. Wilkerson, U. S. Naval Oceanographic Office, Washington, D. C.

## PRESENTATION OF PAPERS

In this section are given the title of the paper presented by each contributor, a resume of the oral presentation of each speaker, and an approximate account of the ensuing discussion. The complete text of each contribution is given in part 2 - - Contributions.

Kirby L. Drennan: Infrared Survey Technique as a Means of Determining Mississippi River Discharge Patterns and Surface Flow Along the Northern Gulf Coast.

The Gulf Coast Research Laboratory is conducting a monthly aerial temperature survey along the northern coast of the Gulf of Mexico. The primary objective of the survey is to determine the variations in Mississippi River discharge patterns and surface currents in the area. The survey is conducted from Grumman Albatross aircraft provided by the U. S. Coast Guard and U. S. Navy. Temperature measurements are made with a Barnes Model IT-2S radiation thermometer and recorded along with input voltage on a dual-pen strip chart recorder. A field test was conducted from a tower off Panama City, Fla., in an effort to determine reliability of the radiometer under varying atmospheric conditions.

The isotherm patterns obtained, along with drift bottle recovery data from inflight releases, have provided a more comprehensive description of surface flow over the area. It is suggested that during the winter and spring months, when surface temperature gradients are strong, greater errors may be introduced by navigational inaccuracies than by instrument inaccuracies. Navigational instruments used include Loran-A, Tacan, and Radar.

In discussion Mr. Drennan mentioned that calibration checks in the laboratory showed a maximum error of  $0.7^{\circ}\text{F}$ . in the instrument as delivered from the factory. Regular inflight checks of the instrument calibration were made. In actual use a maximum variation of  $2.0^{\circ}\text{F}$ . was noted between surface immersion thermometer readings and the IRT, and most of this was thought to be due to expected differences between microsurface and immediate subsurface temperature.

Guy A. Franceschini: Some Factors Influencing the Skin-Temperature of the Sea and Its Measurement by Infrared Thermometer.

Dr. Franceschini described his experience in continuous IRT surface temperature measurement during three traverses between Africa and Antarctica during Spring 1963. The work was done aboard the M/V OB during the 8th Soviet Antarctica Expedition. Over a wide range of oceanographic and meteorological conditions, differences as high as  $5^{\circ}$  to  $6^{\circ}\text{C}$ . were observed between IRT and towed thermistor readings. The greatest variations were recorded after heavy rainfall on the ocean in the Antarctic where the surface "skin", or microsurface, was much warmer than the immediate subsurface. The differences were



shown to be both positive and negative depending upon a variety of environmental influences. Factors involved in the variation between skin temperature and immediate subsurface temperature were given as follows: radiation, sensible heat transfer, latent heat transfer, precipitation, and wind mixing. It was suggested that to reduce problems due to sky reflection, instruments should be calibrated outside of shelter under the sky. The IRT instrument was mounted in the bow of the ship about 40 feet from the surface of the water in such a way that the instrument itself was protected, being mounted above and behind a viewing port in the bow. This was a Barnes instrument with a 2° cone. The thermistor was towed at about 1 meter depth behind the ship. Calibration was the greatest problem in this work; this was done against an immersion thermometer using a bucket of water. A certain amount of variation was shown to exist in instrument accuracy by the bucket checks; this varied up to  $\pm 1^\circ\text{C}$ . Under average conditions the microsurface temperature was about  $0.6^\circ\text{C}$ . In discussion Dr. Franceschini said that he considered that differences to be associated with cloud cover may be appreciable, especially if the IRT is calibrated with a blackbody cavity. For clear sky conditions the difference could be as great as  $1.0^\circ\text{C}$ . *In situ* calibrations minimize or eliminate this variation. Calibration was done with the water in the bucket under strong agitation. The resulting roughened surface approximates more closely the natural sea surface and destroys surface layering. It was not possible to relate the temperature of the rain to the microsurface temperature because no data were available on rain temperature. In dead calm weather the differences between microsurface and immediate subsurface temperature did not increase very much. It was pointed out that reflectivity from the instrument itself may be minimized if the angle of view during calibration is near to but not vertical.

Paul M. Moser: Airborne Infrared Oceanic Mapping

Mr. Moser reported on his experience in using a highly sensitive radiometer which could be calibrated as an IRT, in conjunction with an airborne infrared mapping device which records thermal pictures of the sea surface on photographic film such that cool areas appear dark and warm areas appear light. The scanner permits an area of view of one nautical mile for each 1100 feet of altitude with a scanning angle of  $140^\circ$ . He described the network pattern of cool-edged polygonal spots associated with convection cells at night (about 100 feet in diameter) as well as oil slicks, wind streaks, and sun glare (stressing that sun glare operates at all wave lengths). Meteorological conditions affecting IRT readings were also discussed. White caps were seen to show up typically as cold spots at night. By use of the scanner, both small- and large-scale water motion could be deduced. Mr. Moser concluded that "bucket depth" temperatures should be calculable to within  $0.1^\circ\text{C}$ , from nighttime vertical IRT measurement provided air temperature, wind force, and humidity are known. Nighttime IRT records would give absolute definition of temperature fields of greater accuracy than daytime records when thermal structure is more stable.

In discussion Mr. Moser stated that the IRT sensor was located within the airplane just far enough inside to avoid the slipstream. An air diverter was installed just ahead of the opening so as to provide a gentle air outflow. Mr. Moser qualified the remark made in his preconference notes (which were distributed to those in attendance) by stating that many of the phenomena listed therein can be recorded only if the measuring device has a

sensitivity to sea surface temperature differences of the order of  $0.01^{\circ}\text{C}$ . He also pointed out that he was interested principally in recording point-to-point temperature differences rather than absolute sea surface temperature. Temperature differences can be measured with far greater accuracy than absolute temperatures.

Robert C. Barnes: Infrared Radiation Thermometer - an Evaluation.

Monthly surveys of sea surface temperatures over the Atlantic Shelf between Cape Henlopen, Del., and Cape Hatteras, N. C., have been made by the Virginia Institute of Marine Science since June 1963. Survey flights have also been made in Virginia waters of the Chesapeake Bay and its tributaries. The IRT readings have been checked against immersion thermometer readings from fixed stations and from ships. The largest sources of error came from variations in frequency of the available AC power supply. Battery power supplied through an inverter appeared to give better results overall. Oil slicks were not observed to affect the readings.

John L. Frank: Accuracy of Airborne Infrared Thermometry

The Barnes Engineering Company, which Mr. Frank represents, produces a relatively inexpensive portable infrared thermometer, now in its third production model. The IRT receives radiation from three sources: reflection from the sky, emission from the atmosphere, and radiation from the ocean. The last is the only one of interest and is selected for by the instrument by use of its optical system which accepts energy only in the 8 to 13 micron spectral band. The major interfering factor will be water vapor in the path between ocean surface and radiometer, but these effects can be corrected for if the air temperature and water vapor content are known, providing absolute accuracy of microsurface sea temperature to  $\pm 1.0^{\circ}\text{F}$ . In any event we are measuring only the temperature of the top 0.1 mm. of water. This microsurface is, of course, usually at somewhat different temperature than the immediate subsurface water, as is well known by now. Perhaps the greatest problem in airborne use of the IT-1 or -2 has been variation in line frequency beyond the maximum 1/2 c.p.s. Changes have been made in the IT-2 which improve it over the IT-1 particularly in elimination of "swish" problems -- the importance of closing the detector cavity for airborne operations was realized so that the late models of the IT-2 have completely sealed cavities. Still it is necessary to protect the sensing head from excessive vibration, direct slipstream turbulence, and excessive cooling in cold weather. In-flight calibration checks are suggested in the beginning stages of the instrumental setup to insure overall accuracy of the unit.

In discussion it was brought out that the optical system used on the Barnes IRT is a compromise necessitated by cost in order to keep the price of the instrument down to a reasonable figure. It was suggested to Mr. Frank that the Optical Coating Laboratory in California produces a lens which could provide more specific selection within the desirable 8 to 13 micron band than the Indium Antimonide/Kodak IRtran-2 combination used at present. Mr. Frank agreed that he would look into the matter and as always work in the direction of improving the instrument's potential without substantial increase in price.

Dr. Gifford C. Ewing: Evaporation gradients at the sea surface

Dr. Ewing reviewed his basic studies on the nature of heat transfer in water. Photomicrographs were shown which demonstrated convection current formation. He also discussed the various programs carried out at the Scripps Institute of Oceanography which involved IRT measurements, part of which have been covered in two papers (G. Ewing and E. D. McAlister, Science 131, 1374-76; E. D. McAlister, Applied Optics 3, 609-612). The upper 10 microns of the ocean surface is the active radiation area and this breaks down as follows:

<u>Event</u>	<u>Depth</u>
Evaporation	3 angstroms
Reflection	5 angstroms
Protein-mono layer	30 angstroms
Radiation layer	1,000,000 angstroms

A difference of  $0.6^{\circ}\text{C}$  was measured between the microsurface temperature and a depth of 15 cm. in one test done at night off the Scripps pier. The most rapid area of change in temperature is the first mm. of the surface. Recordings from an airborne infrared scanner showed convection cells and whitecaps. Foam on the surface was shown to have a pronounced effect.

Following Dr. Ewing's presentation there was a discussion of the probable effects of sky reflection. The consensus of this discussion involving Messrs. Moser and Frank was that at a level of accuracy of  $\pm 1.0^{\circ}\text{F}$ ., reflectivity should be no great problem. The effect of error in absolute temperature read-out in apparent displacement of isotherms on thermal maps was discussed. It was also brought out that under "average conditions" the microsurface temperature appears to be about  $0.6^{\circ}\text{C}$ . cooler than the immediate subsurface. Mr. Clark mentioned that the average annual difference shown by the Sandy Hook work was about  $1.0^{\circ}\text{F}$ . Correction for the difference in temperature of this film of water at the surface is a major problem with IRT survey of surface temperature. It was noted that the surface film tends to maintain itself and requires considerable force to rupture it. It is restored to its original condition (relative to the temperature gradient across the microsurface) in about 20 seconds after the breaking of a wave. The wind has to be blowing quite hard in order to produce whitecaps with sufficient frequency to effect this rupture and therefore to significantly affect the gradient across the microsurface when averaged over a fairly large area.

Robert A. Peloquin, John C. Wilkerson, George L. Hanssen: Use of Barnes Model 14-320 Airborne Radiation Thermometer in Aerial Survey Over the North Atlantic

The nominal accuracy of the Barnes 14-320 Airborne Radiation Thermometer (ART) is  $\pm 0.2^{\circ}\text{C}$ . Calibration is conducted with a temperature-controlled bath and usually holds good for up to three weeks. A number of tests have been performed to determine the



possible interference by air turbulence, acoustics, vibration, and shock. The result of these was to show that the most serious interfering influence on the instrument is air turbulence. In tests made to compare ART airborne readings with conventional sea-surface temperature measurements, large differences observed could usually be explained on the basis of water vapor or other known factors. A difference of as much as 1.7°C has been observed. A formula for the correction of water vapor in the air column which was developed by the Weather Bureau was given and discussed. The relation between ART survey and the Synoptic Oceanographic Analysis Program of the Navy was also presented. Generally it can be expected that the ART readings will estimate actual sea-surface temperature within  $\pm 0.4^{\circ}\text{F}$ ., but larger errors which must be continually watched for are caused either by instrument problems or unusual environmental conditions. The Navy considers the primary value of the IRT survey to be in the location of gradients and fronts rather than absolute temperature. The use of the ART in estimating layer depth was demonstrated by a graph showing a negative relation between layer depth and surface temperature. This is important because layer depth is a major factor in determining sonar conditions.

In the discussion that followed it was brought out by Mr. Moser that the more sensitive types of equipment give rise to a completely different set of problems in relation to "sea-noise". The greatest variation seems to occur when the sea is either calm or rough, but at sea states between 1 and 3 the "quietest" pictures are obtained. It was brought out that one source of variation could be eliminated if the "chopper" wheel were not located between the lenses. It was also brought out that occasionally the temperature of the lens was monitored on Navy flights, but that no airborne calibration checks could be made.

John P. Tully: Airborne Radiation Thermometer on the Pacific Coast of Canada

A cooperative IRT survey program is being set up for the North Pacific Ocean by interested Canadian agencies. The object of this is to install unattended airborne IRT into routine military air patrol craft in order to collect a large amount of surface temperature data from the North Pacific at low cost. Experience was obtained initially with Richardson's unit loaned from the Woods Hole Oceanographic Institute and later with a specially built instrument using a Barnes bolometer. At the present time a new model for use in the new program is in the final stages of completion. Of the five units which are being completed, two are for survey on the Atlantic Coast, two on the Pacific Coast, and one for special assignments. Dr. Tully noted that the equipment measures apparent radiation which varies because the ambient variation of sea surface temperature is at least 1°C. He argued that both military and fisheries were concerned primarily with temperature structure in the sea and that temperature *per se* was secondary. One-degree accuracy was sufficient for most purposes. The structure in the sea, occurrence of transients, fronts, etc., are revealed by the character of the recorder "signature" and are a function of sensitivity of the equipment rather than accuracy.

In discussion it was brought out that study is being undertaken by W. L. Godson to determine a practical means of correcting the IRT records to reveal the true temperature to about  $\pm 0.1^{\circ}\text{C}$ . Other work is going on to determine the difference between microsurface and bucket-depth temperature. It is believed that if the IRT instrument can operate with an error limit of  $\pm 0.5^{\circ}\text{F}$ . or less, the aerial survey temperature data will be widely useful. Dr. Tully believes that because "normal ambient" variation is near  $1.0^{\circ}\text{C}$ ., precision to  $0.1^{\circ}\text{C}$ . may not be required in environmental studies.<sup>1</sup>

John Clark and Richard B. Stone: Use of the Infrared Thermometer in Routine Coastal Survey

The Sandy Hook Marine Laboratory has carried out monthly aerial surveys of sea surface temperature over the Atlantic Continental Shelf routinely since December 1962. The basic requirement was to estimate surface temperatures with a maximum of error of  $\pm 1.0^{\circ}\text{C}$ . The greatest problem with this has been that there is no longer a single definable "surface" temperature because of the vertical thermal gradient between microsurface and "bucket depth." To adjust for many sources of error, such as input-voltage variation, bias-battery deterioration (with IT-1), etc., the temperature record was corrected in flight to agree with regular calibration readings against a container of water of known temperature measured by immersion thermometer. The error in temperature readout associated with frequency change was found to be about  $1.5^{\circ}\text{C}$ . for a shift from 59.9 to 61.1 cycles. Repeatability tests were made in cooperation with the Naval Oceanographic Office in which the Navy and Sandy Hook IRT's, in separate aircraft, were flown over the same track.

1 Post workshop note. -- Dr. Tully advised on September 14, 1964:

- (1) Four units of the airborne radiation thermometer (FRB-2) have been completed and are in service with RCAF-Maritime Air Command, as planned.
- (2) The equipment is not as quiet (electrically) as we would like to have had it. The ambient variation of the temperature record, due to internal electrical variation, is about  $0.3^{\circ}\text{C}$ . Final elimination of this "noise" could require many months of research. This level of uncertainty is tolerable in the present state of the art of infrared thermometry, so we have decided to accept it for the present. However, we plan to devote as much time to corrective measures as our work load here will allow.
- (3) Also, we have abandoned the construction of an inflight calibration device, partly because primary calibration using a tub of water is quite satisfactory, and partly because the equipment is temperature stable and does not require in-flight calibration.
- (4) Two units are in service here on the west coast. Two units of the ART have been dispatched to the east coast for equipment proving and evaluation and to support the Information Service there.
- (5) The fifth unit will be used here at Nanaimo to verify the relation between the radiated sea surface temperature and the subsurface temperature and structure. This could not be done until now because adequate equipment was not available. An oceanographic tower has been built in Departure Bay. From it, thermistors will be suspended in the water to record the temperature, structure and variations (heating, cooling, transients, etc.). At the same time the surface condition will be recorded by the ART, at constant height. Finally the records will be correlated and analyzed. This series of tests may continue through next summer (1965).

On 400 miles of transect in which the navigation was good the records correspond very closely. Over the survey area, the average difference between microsurface and bucket temperatures varied from  $-2.0^{\circ}$  to  $+0.7^{\circ}\text{C}$ . throughout the year, with the microsurface on the average  $0.5^{\circ}\text{C}$  cooler. The differences are systematic with season, so that to some extent the difference between microsurface and bucket-depth temperatures can be predicted from empirical data collected over a year's time.

In discussion it was pointed out that if microsurface/bucket-depth temperature relations prove to be systematic and predictable for other parts of the sea as well, there is hope for the development of a workable set of adjustment figures. These coupled with corrections for airpath and sky reflection problems could provide the basis for a comprehensive set of adjustments for the IRT readings to obtain subsurface temperature estimates.

Takashi Ichiye and Noel B. Plutchak: Calibration and Field Testing of the Infrared Thermometer

The Lamont Geological Observatory has been using the infrared thermometer to determine the fine structure of surface water temperature concurrently with field experiments of dye diffusion. A number of tests were made to determine whether the instrument had sufficient accuracy to be useful for this purpose. The results of these tests indicated that there are many factors influencing the readings and great precaution must be taken in order to obtain accurate data. A simple calibration was made by mounting the sensor at 33 feet, 13 feet, and 4 feet from the water surface of a basin 4 feet in diameter and 10 inches in depth with a stirrer keeping water temperature nearly homogeneous. IRT readings were shown to be influenced by air temperature between the sensor and the water surface. Corrections of readings for the airpath of 33 feet reach  $2^{\circ}\text{F}$ .,  $4^{\circ}\text{F}$ ., and  $6^{\circ}\text{F}$ . for water-air temperature differences (water warmer than air) of  $20^{\circ}\text{F}$ .,  $40^{\circ}\text{F}$ ., and  $60^{\circ}\text{F}$ ., respectively. These corrections seem to increase with the length of the airpath between sensor and water. Wind gusts also appeared to affect the calibration checks made from the rooftop of the laboratory. The angle of attach of the sensor appeared to cause problems only when the angle exceeds  $40^{\circ}$  from normal. Repeatability tests made with the Sandy Hook Marine Laboratory, with both instruments used in the same aircraft, gave satisfactory results. An attempt to use a Cessna aircraft for calibration tests failed because of the inadequacies of the airplane's power supply and the effect of the wind and acoustic vibration on the instrument. With IRT mounted on the tower at Panama City (at 100 feet from the sea surface) the instrument was able to detect tide lines, ship wakes, and dye patches.

James L. Squire, Jr.: Observation of Physical Factors Affecting the Use of Airborne Radiometer

The Tiburon Marine Laboratory has been carrying out surveys of surface water temperature along the Pacific Coast since 1962 with the object of determining the relation of sea surface temperature to distribution and abundance of marine fishes. Two models of IRT and five types of aircraft have been used in more than 300 hours of operation. Calibration techniques were discussed along with the methods of developing correction factors for the IRT readings. Field tests were made comparing IRT observation and



immersion thermometer readings taken by surface craft. Checks were also made with surface readings taken from towers and piers. From this it is concluded that when proper operating procedures are followed, the IRT can estimate surface water temperatures within  $\pm 1.0^{\circ}\text{F}$ . The effect of water vapor in the air path was shown to amount to somewhat less than  $-0.5^{\circ}\text{F}$ . at 500 feet altitude, with visibility near the surface of about 6 miles (in November). In preparing isotherm charts for the surveys the instrument is read every 30 seconds in flight and an average is drawn for every two minutes; these are the data points for the isotherm drawings.

In discussion it was explained that it was their procedure to take one observation each 30 seconds and to average it by two-minute periods in order to smooth out any small fluctuations in the data. It was pointed out that problems of interpreting records and drawing isotherms are unique to each area. The need for standardization in interpretive techniques was brought forth, as was the need to accumulate the data in such a way that it can be handled by computers. Mr. Squire mentioned that after plotting the smoothed curves they did then go back and inspect the record and show the fronts separately if they were concealed by smoothing. The consensus appeared to be that continuous inspection of the strip chart record for plotting isotherms was better than averaging or taking selected points along the line. It was pointed out that this is a simpler technique to manage in practice where there are good temperature gradients. The continuous inspection technique was explained to mean that the strip chart record was inspected for increases or decreases past the plotting interval, whether 1 or 2 degrees, and these being only the data point recorded along the flight track. A problem arises, however, with storage and retrieval of these data, about which some general accepted standard should be found.

#### John W. Reintjes: Comments Relative to Infrared Workshop

The Bureau of Commercial Fisheries Biological Laboratory in Beaufort, N.C., has participated in the cooperative program of the SEAS Committee. The method of operation is similar to that used by Sandy Hook Marine Laboratory and the Virginia Institute of Marine Science which, together with the Beaufort effort, extend the monthly synoptic coverage from Cape Fear, N.C., to Cape Cod, Mass. The usual operating problems, as expressed by others who spoke earlier, were encountered in the work. The differences between lightship observations and aircraft IRT readings were as high as  $3^{\circ}\text{F}$ . but tests made in December and April with plane and research vessel gave differences between IRT and bucket-depth temperatures of small fractions of a degree F. The limits of accuracy of the technique appear to be  $\pm 0.5^{\circ}\text{F}$ . which easily meet the minimum for areas of sharp gradient such as are encountered between Cape Hatteras and Cape Fear, N.C.

#### Floyd C. Elder (Extemporaneous Remarks)

The University of Michigan Department of Meteorology and Oceanography has seven IRT instruments in use on various vessels in the Indian Ocean Expedition. The Department also has carried out some work with the Barnes IT-2 on two research ships in the Great Lakes area for studies of energy exchange at the air-sea boundary layer. In the near future there will be some testing operations comparing research tower IRT readings with floating

thermistor readings. Differences between IRT and surface readings have been as high as 1°C.

Carl D. Miller (Extemporaneous Remarks)

The Infrared Laboratory of the Institute of Science and Technology of the University of Michigan has attempted detailed thermal mapping of Lake Erie for the Bureau of Commercial Fisheries. This has been done from a DC-3 aircraft and operating problems have been about the same as those described by others before.

Robert A. Ragotzkie

The Department of Meteorology of the University of Wisconsin has carried out some tests with the IRT during daylight in the summer which have shown the IRT to give higher readings on the average than direct surface measurements, the greatest differences being about 2.0°C. The differences were shown generally to be greatest with calm water, least with rough water, and intermediate with a rippled surface.

Arthur E. Maxwell (Sponsor's Extemporaneous Comments)

"We are impressed with the amount of work that has gone on in IRT research and survey activities, but frankly we are bothered by the lack of precision attained in the present application of the technique. We are also preplexed somewhat by the preoccupation with bucket-depth temperatures as interpreted from the IRT, rather than the use of direct infrared measurement of the microsurface. The instruments employed for most of the survey work to date have severe limitations, and a very critical look should be taken at the working accuracy of the instrument before surveys are commenced. Of course, an understanding of all sources of variations must be greatly enlarged before improvements in the resolution of the instrument itself can benefit us. In the meantime, caution must be taken not to alias the data. Certainly, bringing all this out for discussion this spring is most timely and useful, and this perhaps will mark the turning point in the development of the IRT technique. Now, after some years of unsystematic collection of data, perhaps we can start on the path to more sophisticated techniques in the use of the IRT for surface temperature survey."

In discussion, it was pointed out that we now are able to separate the phenomenological problems from the instrumentation problems and set out to take these up for solution one at a time. Dr. Tully pointed out that the intended use of the data should be considered before undue criticisms can be drawn of the type of work so far carried out. He mentioned that for many ecological uses, for studying fish distribution, etc., we can be much more tolerant of small variations than in many purely physical oceanographic studies and many military uses. For instance, in studying the influence of temperature on fish distribution we are generally looking for areas of sharp transition and if there is an error of a degree in absolute temperature this may not be of great consequence. Thus, IRT survey can be useful even at present levels of understanding and of instrument accuracy, in detecting ocean boundaries and measuring surface temperatures in gradient areas.



## DISCUSSION OF BASIC QUESTIONS

A separate discussion was conducted on each of the 10 basic questions. Such conclusions as could be agreed upon generally are given below. The stated conclusions represent the consensus of the Working Panel, usually unanimous.

### Question 1. What instruments are available for infrared detection of sea surface temperature from aircraft?

- A. The Barnes Engineering Co. "IT-S" family consisting of the IT-1S and IT-2S already in operation and the IT-3S now in production.
- B. The Barnes Engineering Co. ART (14-320 model) which is the most sensitive and expensive type.
- C. Various experimental designs, none of which are in production.
- D. Infrared scanner devices; experimental designs and not commercially available; custom-built models cost about \$30,000.

### Question 2. What are the limits of instrument accuracy of presently available IRT equipment?

- A. Barnes Engineering Company claims the following for the IT-S family:
  1. Accuracy Upper limits are  $\pm 2^{\circ}\text{F}$ . at cold end of scale; somewhat better at warmer end.
  2. Stability Related to ambient temperature and other environmental conditions, but can be close as  $\pm 0.5^{\circ}\text{F}$ . in fixed environment.
  3. Sensitivity (or Resolution) This depends upon the type of recorder, paper size, etc., but  $\pm 0.25^{\circ}\text{F}$ . should be attainable.

The Naval Oceanographic Office claims  $\pm 0.2^{\circ}\text{C}$ . as the possible operating accuracy of the Barnes 14-320 ART instrument. This approximates the stability of the calibration water bath temperature, which is limiting.

The new Fisheries Research Board of Canada design is expected to have a sensitivity of  $\pm 0.2^{\circ}\text{C}$ .

The consensus of those with experience in using IRT instruments in routine survey work is that under favorable conditions  $\pm 0.5^{\circ}\text{C}$ . accuracy can be obtained by careful use of the instrument with controlled environment and frequent calibration checks made in flight. In any event, accuracy of  $1.0^{\circ}\text{C}$ . should be easy to obtain. It must be noted that this is only in reference to microsurface temperatures and not bucket-depth temperature estimates from IRT microsurface readings.

Question 3. What are the important operational problems with infrared thermometers and what possible solutions are there?

Calibration. It was agreed that blackbody calibration would be best. There should be preflight, in-flight and postflight calibration checks for close tolerance work. The water in calibration containers should be kept as near to the prevailing surface temperature as possible. There was recommended a simple blackbody calibrator described as a metal container (rectangular gallon gasoline can) with a black-surface cone immersed in water within it, the temperature of which can be determined by an immersion thermometer, thus giving the temperature of the blackbody cone very closely; an automatic stirrer within the can would be helpful. A factor that would cause error here is the fact that sea-water emissivity is not exactly that of a blackbody; the probable effect of this must be determined.

If a water bath is used for calibration it is important that the water in the container be strongly agitated at the time of the calibration check. If the water is not agitated, calibration error of up to 1.0°C. can result.

It is realized that these solutions cannot apply simply to fixed-mounted instruments in flight but they can work easily for the tripod-mounted IRT.

Power supply. With the IT family of instruments there is a limited tolerance to AC frequency variations. If the input voltage is more than 0.4 cycle off, the instrument should be recalibrated to that frequency. An apparent temperature difference of 1.5°C has been shown to result from a variation of 1.2 cycles. Since many power sources presently used with the IRT are inexpensive inverters with no frequency control, the DC input must be closely watched since the AC output frequency is a function of the DC input voltage. However, frequency controlled inverters which eliminate this problem can be purchased for approximately \$500 (such as one produced by Accurate Instrument Company). The new model IT-3 will have tolerance to operate between 58.7 and 61.3 cycles without significant error. Nevertheless, it is suggested that each instrument ensemble include a frequency meter and a voltmeter on the power input. It was also suggested that Barnes Engineering consider designing IRT equipment for airborne use utilizing line frequencies varying between 380 and 420 c.p.s.

Detector cavity problems. For use in aircraft, with the considerable amount of acoustic vibration experienced, the IRT detector cavity must be tightly sealed. If not, the air within the detector cavity can be set in motion and the record is useless. The late production runs of the IT-1 series and the early runs of the IT-2 series had unsealed cavities and as a result gave poor performance in aircraft; all models now produced are sealed. Further improvement could be made by evacuating the detector cavity.

The sensor head must be kept inside the aircraft and properly shielded and protected from the aircraft slipstream. Rapid air motion over the sensor head will affect the temperature of the optics and possibly the detector cavity itself. Also the speed of the chopper blade can be affected. The best mounting arrangement appears to be such that the opening for the sensor should allow for a gentle outflow of air from the aircraft; this

will provide a more stable environment for operation of the instrument. It was also noted that the view path of the instrument should avoid the exhaust path of the airplane engine.

Vibration. Vibration is not considered an important problem with the instrument on shock mounts. Shock, however, can be a problem and should be avoided.

Moisture on Optics. Problems developing from this source could be eliminated by heating the optics, or more simply by protective location of instrument.

Interference. There can be pronounced effects from radio transmission and an attempt should be made to eliminate such interference. Since the effects are generally induced through the power lines, insertion of R.F.I. (radio frequency interference) filters in the power lines should reduce this to an acceptable level.

Question 4. What limitations are imposed by variable meteorological conditions and to what extent can the effect of any of these be predicted and the data corrected?

The consensus was that effect of the sky reflectivity component could, in practice, cause a variability of  $0.5^{\circ}\text{C}$ . Theoretically the variability could exceed  $1.0^{\circ}\text{C}$ . Water vapor in the air path could, in practice, cause an error of  $0.5^{\circ}\text{C}$ . or even greater error under unfavorable conditions. If all meteorological variables could be properly recorded, corrections could be applied which could reduce the variation to  $0.1$  to  $0.2^{\circ}\text{C}$ . Therefore, it appears of the utmost importance that sky temperature, air temperature, and humidity be accurately measured. It is recognized that measurements would have to be made at various altitudes to detect variations through the air column from the water surface upward.

Humidity. A correction can be made for water vapor with a relatively short air column by measuring the average air temperature in the column and the amount of water vapor and using the following formula developed by the Weather Bureau:

$$t_E = (t_a - t_s) (1 - 0.8^W)$$

where

- $t_E$  = temperature error,
- $t_a$  = mean temperature of the air column,
- $t_s$  = surface water temperature,
- $w$  = optical thickness (measurement of water vapor in the air column), and
- $0.8$  = mean value of transmission coefficients for wave lengths between 8 and 13 microns.



A sample calculation using this formula reported by the Naval Oceanographic Office showed an error of 1.6°F. as the maximum to be found at 1,600 feet. It was brought out that the heterogeneity of the air mass involving temperature and humidity can affect the result of such calculations. It was noted that the amount of water vapor in the air is inversely related to the distance from the surface of the water. It is recommended to stay below the inversion layer when using the IRT. Since error caused by water vapor is a function of the altitude it was pointed out that the closer the plane can fly to the water the better, from an accuracy standpoint. Below 200 feet the problem may in fact be very small. For instance, at 300 feet altitude a typical error correction might be 0.3°F. When there is precipitated or dispersed liquid water, IRT readings should not be attempted since no reasonable correction formula can be supplied.

It was brought out by the technical representative that we should be able to correct the IRT readings to one significant figure if we have information on water vapor, air temperature, absorption, reradiation and sky reflection.

It was suggested that a family of curves be made up for ready correction of the records under various conditions of humidity, temperature, etc., to give rough conversion factors. If a higher degree of accuracy is required, calculations could be made directly from the formula.

Reference to water vapor formula: Meteorological Satellite Laboratory, Report 10, U. S. Dept. of Commerce, Weather Bureau, August, 1962. Infrared Flux in Temperature Determination from Tiros Radiometer Measurement, E. U. Wark, T. Yamato, J. Lienesch.

Wind. The major effect of wind on IRT surface temperature records is to increase evaporation and reduce the difference between the temperature of the microsurface and that of the immediate subsurface. Wind increases evaporation and sensible heat transfer and reduces the microsurface gradient. In extreme heating or cooling situations wind can sometimes have a pronounced effect (up to 2°C. or more). The effect will depend upon the gradient which otherwise would build up in the absence of the wind. In any event it is not possible now to handle this mathematically. Wind is one of the parameters in an analysis now being undertaken at Texas A. & M. on data obtained during the cooperative cruise aboard the OB. On infrared scanner records, whitecaps typically show up as cold patches.

Question 5. What factors other than meteorological act at the air-sea interface to affect the accuracy of the IRT sea-surface temperature determination?

The only factor of possible significance in this connection is contamination, such as "oil slicks", which can affect results when using instruments of sensitivities down to 0.1°C. but have little effect, if any, on survey work where limits of accuracy of 0.5°C. are imposed.

Question 6. In view of the answers to the above questions, what specifically are we measuring when we use the IRT over water?

It was concluded that what is being measured is the temperature of the upper 0.1 mm. of the body of water as modified by attenuation, sky reflection, water vapor, and dispersed liquid water. (This excludes sources of variation introduced by the instrument itself, such as cavity or lens temperature, or that of the atmosphere itself between aircraft and water, which becomes important if the lens system does not have appropriate spectral selectivity).

Question 7. What are the limits of accuracy of data collected with presently available infrared equipment in predicting microsurface temperatures, bucket temperatures, and mixed layer temperatures?

It was concluded that the microsurface temperature can be estimated within  $\pm 0.5^{\circ}\text{C}$ . with proper use of the IRT equipment. It was also concluded that with adequate supplementary data bucket temperatures could be estimated within  $1.0^{\circ}\text{C}$ . from IRT microsurface temperatures. This requires that corrections or adjustments be made which require specific knowledge of the effect of meteorological conditions on the difference between microsurface and immediate subsurface temperatures. Data are now coming to hand from which predictions of the heat budgets and transfers can be made but a considerable expansion of effort in collecting these data is required. Some differences as large as  $3.0^{\circ}\text{C}$ . remain unrationalized, but it is thought these could have been caused by operational error or extreme microsurface gradient for which no correction data are available.

It was concluded that mixed layer temperatures could be predicted to some useful extent, nominally  $\pm 3.0^{\circ}\text{C}$ . Useful estimates of the temperatures of the mixed layer from IRT records can be obtained if knowledge is at hand on prevailing gradients from surface to the thermocline for the specific locality and season involved. This information is a matter of record for many areas from existing bathythermograph data.

Question 8. What can be done to standardize the collection, reporting, processing, and storage of IRT data and expedite its retrieval and dissemination?

The National Oceanographic Data Center agreed to take this question under advisement and to prepare a proposal.

Question 9. What are the best uses to which the presently available IRT data can be put?

For deep sea oceanography, IRT data are useful in detecting horizontal gradients; the value of absolute temperature readings is doubtful, since accuracy of  $\pm 0.1^{\circ}\text{C}$ . or better is often required. There may be more useful applications for physical studies in the shallow areas where hydrographic features can be more readily interpreted from surface thermal patterns.

River discharge patterns and large-scale circulation patterns are evident in the shallow-water isotherm plottings now available from IRT work such as that carried out in the Gulf of Mexico.

The Naval Oceanographic Office can utilize all IRT data for the Continental Shelf and Slope for defense purpose.

From an ecological standpoint the location of thermal gradient boundaries may be more important than reporting of absolute temperatures for many purposes.

It was concluded that the continuance and expansion of IRT survey activity should be encouraged, including the distribution of the isotherm maps, but they should be interpreted with the above sources of variation in mind.

For air-sea interface studies involving energy exchange it is necessary to have absolute temperature to an accuracy of  $\pm 0.5^{\circ}\text{C}$ . or better.

IRT survey data for an area will increase in value with the number of known temperature reference points at the sea surface with which to interpret or adjust the infrared readings. IRT data will serve to greatly enlarge the information that can be obtained from surface operations if planned conjointly with the surface work.

Question 10. What possible improvements could be made to reduce sources of error in presently available IRT equipment?

It was concluded that the most expeditious method of handling this matter was to request the Barnes Engineering Company to solicit from present IRT users their opinions on improvement of the instrument. The Technical Representative agreed to see that this was being done.

## CONTINUED IRT SURVEY AND SECOND WORKSHOP

It was concluded that IRT survey work should be continued and expanded where possible to fill in important areas not now surveyed. For the Atlantic Shelf, extension to the Gulf Stream frontal area would be desirable as would increasing the frequency of observations from monthly to biweekly. It was thought that the Office of Naval Research and the National Academy of Science might show interest in supporting this activity. It was also recommended that survey activities be coordinated through interlaboratory organizations such as the SEAS Committee for the Atlantic and EPOC for the Pacific. The U.S. Coast Guard was considered the best source of assistance in the aerial operation and its cooperation should be requested.

It was also concluded that a second infrared workshop should be convened in order to provide for more detailed consideration of the technical problems of IRT survey. It should not be held until the winter of 1964 - 65, or as soon after as possible, to take maximum advantage of the considerable amount of work planned for the remainder of this year.

It was agreed that the value of a second workshop could be enhanced if the considerable amount of infrared work already done under defense contracts could be declassified. It was recommended that ONR and NASCO would be the most appropriate agencies to work toward declassification of infrared sea surface temperature data.

The following persons agreed to provide liaison with certain agencies interested in IRT survey work:

Interagency Committee on Oceanography: Bernard E. Skud.  
Eastern Pacific Oceanographic Committee: James L. Squire, Jr.  
National Academy of Sciences Committee on Oceanography: John Clark.  
Committee for SEAS: John Clark.

It was recommended that the proceedings of the Workshop be brought to the attention of these groups and that an acknowledgement of the level of their interest in IRT survey work be obtained.

Copies of the proceedings will be sent to all other organizations thought to have interest in the discussions of the workshop.

John Clark  
Sandy Hook, N. J.  
August 20, 1964







PART 2 — — CONTRIBUTIONS



# ACCURACY OF AIRBORNE INFRARED THERMOMETRY

By John L. Frank  
Barnes Engineering Company, Stamford, Connecticut

## INTRODUCTION

A diagram of the measurement situation appears in Figure 1. The Infrared Thermometer is airborne and looks downward more or less vertically to the surface of the ocean. It is normal to speak of the Infrared Thermometer receiving radiation from the ocean surface; that is, the radiation is thought to flow upward from the ocean to the radiometer. This is not accurate, since the Infrared Thermometer is actually a differential radiance comparator: it both receives radiation from the ocean, and radiates to the ocean (the ocean receives radiation from the Infrared Thermometer).<sup>1</sup> The actual signal developed by the Infrared Thermometer is the difference between the radiation received from and emitted to the ocean; and since the Infrared Thermometer's optics are at a higher temperature than the ocean, the ocean receives more energy from the Infrared Thermometer than vice versa; the net flow of radiant energy is downward from the Infrared Thermometer to the ocean surface. However, the convention of considering that the radiation flows upward from the ocean to the radiometer will be adopted.

Radiation from the ocean passes through the atmosphere, whose characteristics will be considered to be approximately uniform over the entire path length, usually less than a thousand feet. Some of the radiation from the ocean is absorbed by this atmosphere; furthermore, the atmosphere also emits radiation of its own. One other radiation signal must be considered, and that is the reflected signal from the sky; the ocean is not a perfect emitter and does reflect some foreign radiation as indicated in Figure 1. Thus, the Infrared Thermometer receives radiation from three different sources, only one of which is of interest: reflections from the sky, emissions from the atmosphere, and the radiation of interest from the ocean. Furthermore, the radiation from the ocean is somewhat modified by the atmosphere before it reaches the Infrared Thermometer.

## CORRECTION OF ERRORS

### Fundamentals of Infrared

All objects in the universe, whose temperature is above absolute zero, emit radiation. The wavelength of this radiation depends upon the absolute temperature of the object according to Planck's equation and Wien's displacement law. Planck's equation is as follows:  $W_{\lambda} = C_1 \lambda^{-5} \left[ \exp(C_2 \lambda^{-1} T^{-1}) - 1 \right]^{-1}$ . If this equation is plotted for any particular value of T (absolute temperature), a curve will result indicating that the radiation

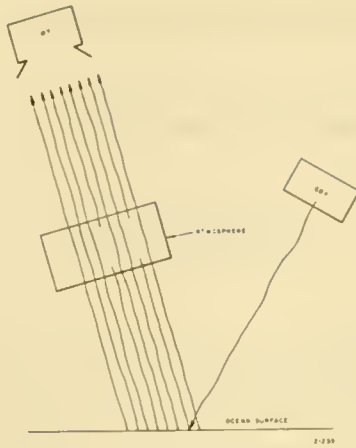

Figure 1. Airborne IRT Measurement Situation

from this object occurs in many different wavelengths and is a maximum at a particular wavelength. These wavelengths, for most objects familiar to man's environment, that is to say, in the general neighborhood of  $300^{\circ}$  Kelvin, occur in the general vicinity of  $10\mu$  and, in fact, Wien's displacement law is  $\lambda_{\max} = \frac{3000}{T}$  where T is given in degrees Kelvin. The foregoing comments have applied only to perfect "ideal" radiators, or "blackbodies". By definition, a blackbody has an emissivity of 1; it is a perfect radiator according to Planck's equation, and since a good emitter is a good absorber, it will also absorb all of the radiation which impinges upon it from an external source. It is "black". As a practical matter, the emissivity of objects is less than 1 and varies with wavelength. This is referred to as the spectral emissivity of an object, and as a matter of fact, an object may have a high emissivity in the infrared and a low emissivity in the visible portion of the spectrum. A good example of this is ordinary paint. Enamel has an emissivity of greater than .9 throughout most of the infrared region of the spectrum, regardless of its visible color.

Another point to be made is that of the equivalence of the terms "emissivity" and "absorptivity". A graybody with an emissivity of 0.5 will emit (radiate) exactly one-half as much energy at any wavelength as an ideal blackbody at the same temperature. Also, it will absorb exactly half the radiation which impinges upon it from an external source. Thus, the oft-heard expression, "a good absorber is a good emitter".

All objects possess the three properties of absorptivity (emissivity), reflectivity, and transmissivity, and these three co-efficients must add up to 1 at every wavelength. Thus a perfect blackbody whose emissivity is 1 has zero reflectivity and zero transmissivity. A non-blackbody, or object whose emissivity is less than 1 may have transmissivity, such as a thin plastic film, or reflectivity, such as a piece of shiny metal, or both.

Having reviewed the basic physics necessary to understanding radiometry, let us apply these principles to our specific situation. Let us start with the ocean surface. What are its infrared characteristics? Over different parts of the world, the temperature of the

ocean surface ranges from a minimum of  $-2^{\circ}\text{C}$  to a maximum of  $+35^{\circ}\text{C}$ . Figure 2 plots Planck's blackbody radiator equation for these two temperatures. Note that 98% of the radiant energy occurs at wavelengths longer than  $6\ \mu$ . From the standpoint of the target radiation, we may confine ourselves to the infrared portion of the electromagnetic spectrum which lies beyond  $6\ \mu$ . Other considerations also make this desirable, as will be shown; therefore, our measuring equipment will be designed to operate at wavelengths beyond  $6\ \mu$ .

Figure 2 plots the radiation of ideal blackbody radiators, that is, targets whose emissivity is 1 at all wavelengths. Unfortunately, the ocean is not a perfect blackbody radiator. To what extent does it deviate from ideal? Figure 3 shows the emissivity of the ocean for wavelengths from  $6\ \mu$  to  $15\ \mu$ .<sup>2</sup> In the region from  $8\ \mu$  to  $14\ \mu$ , the average emissivity of the ocean is .98 or 98% when viewed normally. Now the three properties — emissivity, reflectivity, and transmissivity — must equal 1. Since liquid water of 1 millimeter or greater path length has a transmissivity of zero in the infrared, a 98% emissivity indicates that reflectivity is 2%. Figure 3 also shows that the average emissivity of the ocean in this wavelength region reduces to about 96% when viewed at an angle  $60^{\circ}$  from normal, that is, 4% of energy received by any measuring system is reflected (from the sky).

Another important characteristic of the ocean surface is the difference between the surface temperature and the sub-surface temperature; this will be discussed later.

Having established the radiation characteristic of the ocean surface, consider what happens to this radiation on its journey from the ocean to the Infrared Thermometer. The most severe atmospheric attenuation in the infrared results in selective absorption by gases in the atmosphere. In order of decreasing importance, these gases are: water vapor, carbon dioxide, nitrous oxide, ozone, oxygen, methane, carbon monoxide.<sup>3</sup> Of these, oxygen, carbon dioxide, nitrous oxide, and methane are stable and uniform in concentration. Water vapor is highly variable in concentration, and is stratified; this factor can be ignored since accurate measurements require that the pilot fly the measuring aircraft

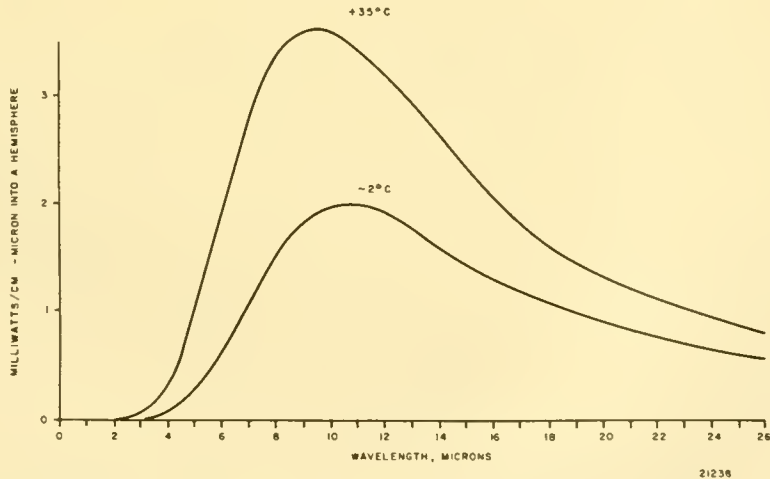

Figure 2. Blackbody Radiation (Planck's Equation)



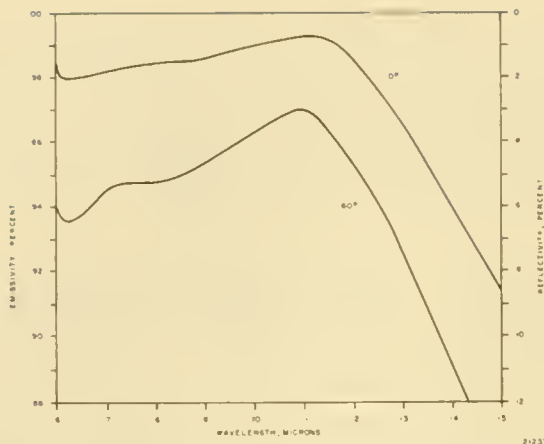

Figure 3. Spectral Emissivity of Ocean Surface at Normal Incidence and 60° from Normal

sufficiently low that this stratification can be ignored. (More than 90% of the water vapor in the atmosphere occurs at altitudes below 15,000 feet; it is necessary to fly much lower than this to make accurate measurements.) Of course, since a good absorber is a good emitter, the very water vapor which absorbs the infrared radiation also emits infrared radiation of its own. Before considering the absorption by water vapor in detail, it should be mentioned that another atmospheric phenomena which attenuates infrared radiation is scattering, caused by liquid and solid particulate matter, and dependent on the number of particles present, their size, shape, density, and electrical characteristics. If treated from a fundamental standpoint, the problem of calculating the scattering effect is complex. It is necessary to make measurements only on days in which the particulate matter in the atmosphere is at a minimum; it is not practical to try to make accurate ocean measurements from an aircraft during a snow storm, fog, rain, or extraordinarily heavy smoke. By confining measurement to good weather days, scattering phenomena may be ignored and, in fact, it is possible to ignore absorption by all gases except water vapor. Figure 4 shows the transmission of the atmosphere in the wavelength region of interest. A striking feature of this phenomenon is that the infrared absorption by the various gases in the atmosphere is localized into regions or bands of high absorption. These bands are vibration-rotation bands of gas molecules. Homo-nuclear molecules, such as oxygen ( $O_2$ ) and nitrogen ( $N_2$ ), do not have absorption bands of this type. Between these absorption bands lie regions of moderate or no selective absorption. These regions of relatively good transmission are called "atmospheric windows" and are defined and numbered for convenience. The region from  $6\mu$  to  $15\mu$  is usually called window No. 8, and it is in this region that most of the radiation from the ocean target occurs. Figure 4 indicates the spectral transmission in this region over a sea level path 1,000 feet long. More detailed data in Reference 4 presents measurements of the atmospheric transmission over pathlengths of 1,000 feet, 3.4 miles, and 10.1 miles over Chesapeake Bay. There is relatively little absorption within the region from  $8\mu$  to  $13\mu$ . This suggests that by utilizing optical filters in a radiometer system to exclude all wavelengths shorter than  $8\mu$  and longer than  $13\mu$ , absorption will be minimized. As a

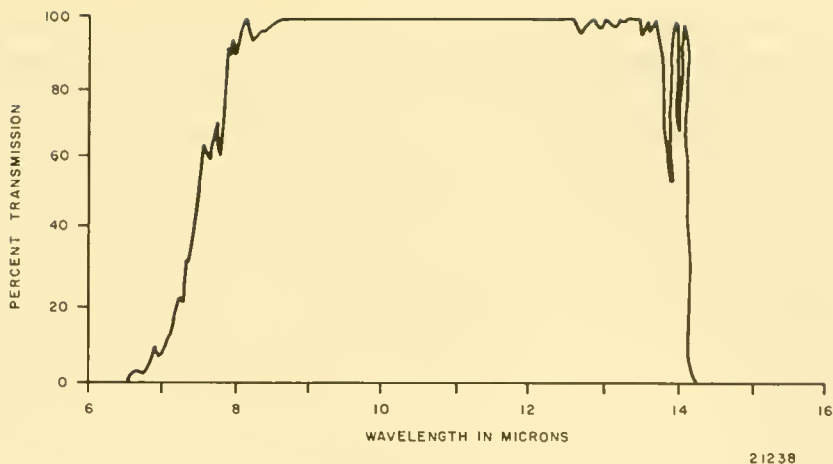

Figure 4. Transmission of Atmosphere (Sea Level, 1000 Feet Path, 0.1 cm Precipitable Water)

practical matter, we must accept a spectral passband obtainable from practical, reliable filters. The filters in the Barnes Infrared Thermometer are Indium Antimonide, which passes wavelengths longer than  $8\mu$ , and Kodak Irtran-2, which transmits all radiations shorter than  $14\mu$ ; the spectral passband is thus  $8\mu$  to  $14\mu$ . An alternative choice would have been Indium Antimonide and Arsenic Trisulfide, which cuts off at  $12\mu$ . Unfortunately, the transmissivity or transmission efficiency of Arsenic Trisulfide is rather low and the signal receivable by the detector with this choice would have been considerably lower, resulting in more noise in the instrument output than is obtained with the Indium Antimonide - Irtran-2 combination. Figure 5 shows the spectral passband of the Barnes Infrared Thermometer.

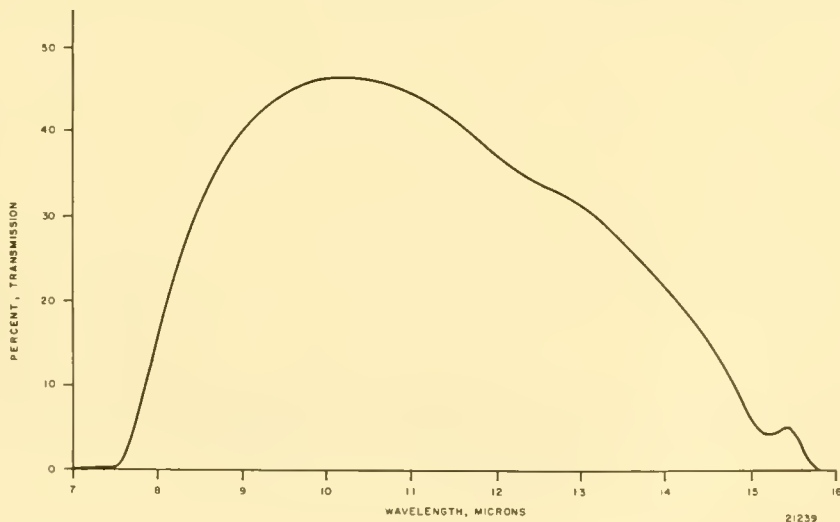

Figure 5. Spectral Passband of Barnes Infrared Thermometer, Model IT-2

We shall confine our attention to the atmospheric absorption between  $8\mu$  and  $14\mu$ , and we note that this is due almost entirely to water vapor. It is, in fact, a function of the amount of water vapor present in the path between the ocean and the Infrared Thermometer, and this is independent of the presence of other gases. We can, therefore, consider the water vapor as a separate "atmosphere" and employ its pressure as a means of stating the quantity present, under the name vapor pressure. Like the pressure in the atmosphere, it can be measured in inches of mercury, millimeters of mercury, or millibars.\* The value of the vapor pressure is independent of the presence of other gases; hence, it is incorrect to speak of air saturated with vapor as one might speak of a sponge saturated with water; it is really the space which is saturated with water vapor. Before proceeding further, we should confess that the absorption due to the presence of water vapor is not exactly a function of precipitable water vapor alone. There are other interfering factors, such as pressure broadening: as the pressure of other gases increases, there are slight variations in the absorption of an equivalent total amount of water vapor as the path length changes, but these effects are minor and can be safely ignored for low flying altitudes.

The entire problem of atmosphere is narrowed down to the following: how much total water vapor is present in the path between the ocean surface and the radiometer? Relative humidity is not the quantity of interest; the amount of water vapor in the path is the quantity of interest. Therefore, we must compute the total quantity of precipitable water vapor in the path. This can be done from temperature and relative humidity data. Figure 6 plots the precipitable water vapor versus air temperature for a 1000 foot path and 100% relative humidity.<sup>5</sup> For other flying altitudes and other humidities, simply apply linear correction factors. The major forms of spectral atmospheric transmission

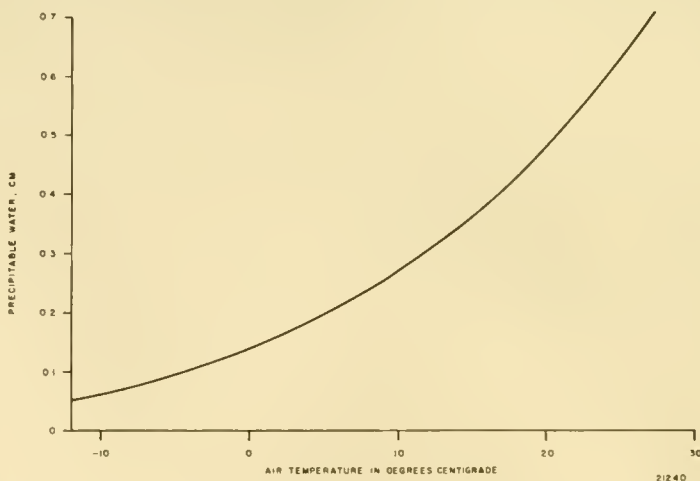

Figure 6. Precipitable Water versus Air Temperature at 1000 Feet Altitude, 100% Relative Humidity

\* 1 bar =  $10^6$  dynes per square centimeter, 1 mm mercury = 1.3332 millibars, 760 mm mercury = 1013.2 millibars, 1 millibar =  $3/4$  mm mercury.



obtained by Yates and Taylor, which are available from the original Naval Research Laboratory Report, reference 4, and are reproduced in Holter, et al, reference 3, have been used to plot the average transmission in the  $8\mu$  to  $14\mu$  band used by the Barnes Infrared Thermometer. The average transmission versus precipitable water vapor present is shown in Figure 7. Given the flying altitude and absolute humidity (or the relative humidity plus air temperature), we can determine the quantity of precipitable water vapor in the path between the airborne Infrared Thermometer and the ocean; and from Figure 7 we can determine the transmissivity of the atmosphere seen by the Infrared Thermometer. This can be substituted into an equation which will be shortly developed, along with air temperature to give the error which is introduced, so that our raw data can be corrected. Although strictly empirical, this technique should normally provide an absolute accuracy of better than  $1^\circ\text{F}$ .

To the extent that the atmosphere absorbs the ocean signal, it also emits a signal of its own, which cause an additional error, but which is also corrected out in the same equation.

One further signal remains to be considered. This is the signal which is reflected from the ocean. On days in which considerable atmospheric absorption exists, this reflected signal is merely more atmosphere. On a day in which no atmospheric absorption whatever is present, this signal would be cold sky, or outer space. On intermediate days in which small atmospheric absorption is present, the reflected signal is neither lower atmosphere nor cold outer space, but something in between. Normally, the solid angle of "sky" seen by the radiometer is nearly a hemisphere, since the wave slopes on the surface of the ocean reflect much "horizon". Certainly much of the 6.28 steradian viewed by reflection consists of sufficient air paths to be relatively opaque. In the extreme case of a perfectly smooth, flat,  $27^\circ\text{C}$  ocean surface and a 100% transmissive atmosphere, the "sky error" would be  $1.5^\circ\text{C}$ . Ewing and McAlister<sup>7</sup> found that a clear sky at night produced an apparent ocean surface temperature a few tenths of a  $^\circ\text{C}$  colder than actual.

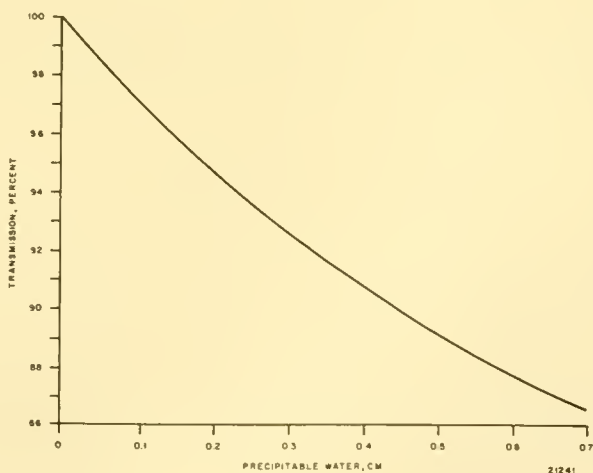

Figure 7. Average Transmission of the Atmosphere vs. Precipitable Water, 1000 Feet Path, 8-14 Microns

Another interesting effect is the rejection of reflected sunlight by the radiometer. Spectral measurements have been made looking directly at the reflection of the sun from a river surface, indicating that the reflected energy is large at wavelengths shorter than about  $5\mu$ , but that at longer wavelengths the reflected radiation contributed by the sun is much less than that emitted by the water.<sup>8</sup>

Sky errors can, therefore, be reasonably ignored in the derivation of the equation.

The radiant power  $P$  arriving at the detector in the Infrared Thermometer is given by  $P = f_o P_{ocean} + f_a P_{atmos} + f_r P_{refl}$  where  $P_{ocean}$ ,  $P_{atmos}$ , and  $P_{refl}$  are the radiant flux received from the ocean, from the atmosphere, and by reflection, respectively; the co-efficients  $f_o$ ,  $f_a$ , and  $f_r$  represent the fractional portion of each of these radiation sources which lies within the spectral passband of the Infrared Thermometer, i.e.,  $8\mu$  to  $14\mu$ . According to the Stefan-Boltzmann law, this may be re-written  $P = f_o \sigma \epsilon t T_o^4 + f_a \sigma a T_a^4 + f_r \sigma r t T_r^4$  where  $\sigma$  is a constant,  $t$  is the transmissivity of the atmosphere,  $\epsilon$  is the emissivity of the ocean,  $a$  is the absorptivity of the atmosphere,  $r$  is the reflectivity of the ocean surface, and  $T_o$ ,  $T_a$ , and  $T_r$  are the absolute temperatures of the ocean, atmosphere, and "reflected" targets respectively.

We can simplify the expression by making several approximations (which are all valid in the practical case), namely:

$$T_r \doteq T_a$$

$$f_o \doteq f_a \doteq f_r$$

Thus,  $P' \doteq \sigma \epsilon t T_o^4 + (a + r t) \sigma T_a^4$ . But  $r = 1 - \epsilon$  and  $a + t \doteq 1$ . Therefore,

approximately,  $\frac{P'}{\sigma} = \epsilon t T_o^4 + (1 - \epsilon t) T_a^4$ . This is the "indicated" temperature and will

be hereafter referred to as  $T_I$ :  $T_I^4 = \frac{P'}{\sigma} = \epsilon t T_o^4 + (1 - \epsilon t) T_a^4$ .

Re-arranging,

$$\epsilon t T_o^4 = T_I^4 - (1 - \epsilon t) T_a^4$$

$$T_o^4 = \frac{T_I^4 - (1 - \epsilon t) T_a^4}{\epsilon t}$$

$$T_o = \sqrt[4]{\frac{T_I^4 - (1 - \epsilon t) T_a^4}{\epsilon t}}$$

This is the desired expression for true ocean surface temperature. Obviously, if  $\epsilon$  and  $t$  were both unity, the expression reduces to  $T_o = T_I$ . In practice,  $\epsilon$  can be taken as 0.98 and  $t$  can be obtained from the curves as indicated previously.  $T_a$ , the air temperature, is measured and these three terms substituted into the above equation to "correct" the indicated temperature, thus giving (approximately) the true ocean surface temperature.

The foregoing has dealt with the problem of accurately measuring the temperature of the surface of the ocean. What is meant by "surface"? According to Ewing and McAlister<sup>6</sup>, the absorption in the region from  $6\mu$  to  $20\mu$  by water is so high that 98% of the absorption occurs in the first 0.1 mm. In other words the radiation measured by the Infrared Thermometer is received from the first three or four one-thousandth's of an inch of ocean surface. Thus, we are measuring the very top of the ocean and the temperature of this micro-surface is different than the temperature of the sub-surface water. Ewing and McAlister performed some measurements in 1959 off Scripps' Pier at the University of California, and found that the micro-surface was approximately  $0.6^\circ\text{C}$  cooler than water 15 centimeters below the surface. They reported that the conditions of wind and humidity were not conducive to vigorous evaporation; although they did not record the temperature and relative humidity at the time of their measurements, the evaporative cooling of the surface could presumably be considerably higher under certain conditions. They then submerged a pump which welled the 15 cm. deep water up to the surface to "rupture" the surface. The radiation temperatures then rose approximately to the same temperatures as those measured by a thermometer submersed at the pump intake. When the pump was shut off, the radiation temperature of the surface dropped about  $0.6^\circ\text{C}$  in about 12 seconds.

The ocean, in ice-free latitudes, is heated to a considerable depth by short wavelength solar radiation. The heat balance is maintained largely by evaporative cooling and long wavelength re-radiation from the micro-surface. More work needs to be done with regard to the difference in temperature between the micro-surface and the sub-surface under different conditions of weather. Until further information is at hand, the best we can do is to carefully note temperature, relative humidity, and wind conditions at the time of all of our measurements, in addition to sub-surface temperatures as obtained by lightships, if possible.

## PRACTICAL HARDWARE

This section deals with some of the practical problems which may be encountered in using the hardware. Generally, this consists of those problems of getting one of several models of the Infrared Thermometer which have been produced, to operate in the airborne environment with its noise, wind, vibration, temperature fluctuations, and lack of correct electrical power. There is also the problem of operating a chart recorder under the same circumstances. The early Barnes Infrared Thermometer (the IT-1) utilized batteries to bias the detector. These batteries exhibited an operating life on the order of 60 to 100 hours. The Model IT-2, which succeeded the IT-1, was fundamentally identical in principle except for a more readable output meter and an electronic bias supply which eliminated



the batteries. Both of these units are capable of tolerating wide variations in power line voltage. Both are critical, however, of the line frequency, which should be within about 1/2 cycle of the specified 60 cycles per second. Thus, a common problem in utilizing them on inverter or vibrator-type power supplies is that the frequency of the supply may be neither sufficiently accurate nor sufficiently stable. At least one user, upon finding his inexpensive inverter operated at a constant 61.8 cycles per second, calibrated his unit at that frequency using the actual inverter in his calibration laboratory. This gave him correct readings on the inverter, but the instrument would read in error when plugged into the 60 cycle power line. A better solution is the purchase of an inverter whose output frequency is accurately controlled. A suitable, inexpensive inverter is the Accurate Instrument Co. unit, costing about \$500.00.

The power consumption of the Infrared Thermometer depends upon the temperature of the air within the aircraft, but is approximately 15 watts for the IT-1, and 25 watts for the IT-2. Since most recorders consume very little power, and since the smallest inverters commonly available put out at least 50 or 100 watts, it is quite feasible to operate both the Infrared Thermometer and the chart recorder from a common inverter, which converts the 12 or 28 volts dc available in the aircraft to 110 volts, 60 cycles for operation of the instruments.

A common recorder problem arises, however, with both the IT-1 and IT-2. The recorder-drive circuit used in these instruments is of such a nature that it requires that the input terminals of the recorder be completely floating; if either terminal is connected to ground or chassis, either directly or through a resistor or capacitor, erroneous readings result. It is usually possible to remove the short circuit, resistor, or capacitor by opening up the recorder.

Late models of the IT-1 and early models of the IT-2 used non-sealed detectors' cavities. In environments where the acoustic noise was high, this permitted a "swish" noise to be present on the signal as air currents rushed back and forth in front of the detector flake. Current production insures an air-tight seal around the cavity to eliminate this possible source of noise. The Infrared Thermometer head, however, is somewhat sensitive to vibration, since it contains components which must handle extremely small electrical signals. Any serious vibration of the head will introduce spurious signals and produce a noisy output indication. It is generally possible to mount the head in such a way so as to reduce the vibrations transmitted directly to it. It should, of course, be placed well within an aircraft and not in the slip stream or in a location where severe drafts or air currents are present. It must also have a clear view of the ocean; it is not feasible to try to look through any windows on the aircraft. It is capable of operating in ambient temperatures from 35°F to 105°F, and its stabilized internal reference cavity insures that it will maintain its specified accuracy over this ambient range. If it is necessary to operate in colder ambients, external heat must be applied to the unit. This may be done by small heating blankets, which can be wrapped around the head and around the main electronics unit.



Until confidence is built up in the instrumental set-up, it is a good idea to carry a pail of water with an immersion thermometer along on the trip. This pail of water can be held in front of the optical head of the Infrared Thermometer at periodic intervals to ascertain correct performance of the Infrared Thermometer. The water must be agitated vigorously before and during these calibration checks, since if permitted to stand even for a few moments, the surface will cool by evaporation; vigorous agitation insures adequate mixing of the cooler surface water with the sub-surface water as measured by the immersion thermometer.

The IT-2 contains an internal response-time switch which provides a fast response when required, as, for example, if "rapid" temperature variations within bays or inlets are to be studied, or a slow response, providing less noise and greater resolution. For our purposes, the slow position is usually of more value.

The current production run of the IT-2's should be exhausted within a few weeks, and the next production run, ready for August delivery, will incorporate numerous changes as a result of suggestions made by users, in order to eliminate some of the aforementioned problems. These changes will now be discussed.

A major change is a different recorder-drive circuit, one terminal of which is grounded, permitting it to drive any electronic recorder whether or not the recorder input is floating. This circuit is designed to drive all standard high-impedance electronic recorders and has an adjustable output from 0 to 50 millivolts.

The most significant change is a more elaborate electrical signal filter which will permit the instrument to maintain specified accuracy for line frequency variations from 58.7 to 61.3 cycles, permitting the instrument to be utilized with inexpensive, inaccurate, unstable vibrator-type inverters.

The microphony of the sensing head has been reduced by an improved optical and mechanical design. It will be less susceptible to noise and vibration and is capable of operating without additional sources of heat in ambient temperatures down to 0°F. An improved open-sighting arrangement has been employed for locating the field of view.

The main electronics unit has a more reliable means of containing the printed circuit boards, and contains numerous external cosmetic changes. These include a comfortable carrying handle, a tilt-up bail for easier meter viewing, and a larger readout meter simultaneously calibrated in both °C and °F. The power line fuse and the response time-constant switch have been moved to the front panel. A more reliable method of holding the chassis in the carrying case has been developed. The meter face will be silk-screened for greater accuracy and more professional appearance. The new model, although generally quite similar to the IT-2, will be designated the IT-3.

## REFERENCES

1. Clark, J. R., and J. L. Frank, "Infrared Measurements of Sea Surface Temperatures." Undersea Technology, 4, 20-23 (1963).
2. Private communication, E. D. McAlister to I. L. Eisner.
3. Holter, M. R.; Nudelman, S.; Suits, G. H.; Wolfe, W. L.; and G. J. Zissis, Fundamentals of Infrared Technology, MacMillan, New York, 1962.
4. Yates, H. W., and J. H. Taylor, Infrared Transmission of the Atmosphere, Naval Research Laboratory Report No. 5453 (June 8, 1960).
5. Berry, F. A.; Bollay, E.; and N. R. Beers, Handbook of Meteorology, McGraw-Hill, New York, 1945.
6. Ewing, G., and E. D. McAlister, Science 131, 1374-76.
7. E. D. McAlister, "Measurement of Total Heat Flow from the Sea Surface," Applied Optics, 3, 609-612.
8. Eisner, I. L.; Bell, E. E.; Young, J.; and R. A. Oetjen, "Spectral Radiance of Sky and Terrain at Wavelengths between 1 and  $20\mu$  ; III: Terrain Measurements". J. Optical Society of America 52, 201-209 (1962).

# AIRBORNE INFRARED OCEANIC MAPPING

by Paul M. Moser, U. S. Naval Air Development Center,  
Johnsville, Pennsylvania

## INTRODUCTION

Since October 1957 the U.S. Naval Air Development Center has been conducting studies of the sea surface by means of an infrared radiometer and a variety of infrared mapping devices installed in aircraft. Quantitative information on both intensive and extensive variables of the sea surface are obtained. The radiometer measures infrared radiation emitted and reflected by the sea surface along the flight path of the aircraft; the mapping devices provide thermal pictures which reveal the size, shape and structure of thermal patterns on the sea surface. In this manner, it is possible to identify fluctuation of the recording pen of the radiometer (that might otherwise be disregarded as "noise") with the surface thermal expressions of a large variety of oceanic phenomena.

## INSTRUMENTS

The radiometer, which was built by Barnes Engineering Company, has an 8-inch diameter, f/1.5, Cassegrainian optical system and employs two germanium-immersed thermistor bolometer detectors yielding angular fields-of-view of  $2.0^\circ$  by  $0.4^\circ$ . The noise-equivalent-temperature-difference (sensitivity) of the radiometer is  $1.3 \times 10^{-3} C^\circ$ . In flight, this sensitivity is degraded to approximately  $0.01C^\circ$ .

The infrared mapping devices are essentially scanning radiometers whose outputs are recorded on photographic film as continuous-tone thermal pictures of the sea surface. Representative equipments used belong to the Reconofax family of infrared mapping devices built by HRB-Singer, Inc. The pictures produced are "strip-maps" whose widths correspond typically to a distance of 5.5 times the altitude of the aircraft and whose lengths correspond to the distance traveled by the aircraft while the device is operating. The sensitivities of the mapping devices can be made comparable to that of the radiometer.

## OBSERVATIONS AND CONCLUSIONS

The following is a summary of observations and conclusions based upon studies of thermal pictures of over one hundred square miles of ocean surface.

- A. Factors that act at the air/sea interface to influence infrared radiation thermometer (IRT) readings.
  1. Evaporation (Rate of evaporation is a function of air temperature, water temperature, solar irradiation, humidity, wind speed, surface films.)

2. Convection (In calm seas at the onset of convection of sea surface is covered by thermal spots -- the surface expression of convection cells -- which are roughly pentagonal or hexagonal in shape. These spots have warm centers and cool edges and may have diameters of the order of one hundred feet.)
  3. Oil films, slicks (The primary effect from oil films seems to be an increase in reflectivity of the surface.)
  4. Wind streaks
  5. Sun glare and glitter (These factors can become very serious at large viewing angles relative to the vertical.)
  6. Waves (Waves become a significant factor at viewing angles in excess of 30°.)
  7. Whitecaps
  8. Currents in the vicinity of islands, over reefs and along shorelines
  9. Swirling where currents converge or diverge
  10. Oceanic fronts
  11. "Fresh" water from lakes, streams and melted ice "floating" on more dense salt water
  12. Water depth (for shallow secluded waters)
- B. Meteorological conditions that affect IRT readings.
1. Atmospheric temperature inversion layers
  2. Nascent and evanescent clouds
  3. Concentrations of water vapor in the vicinity of clouds
  4. Fog, clouds (In the absence of sunlight the temperature of the fog or cloud is recorded.)
  5. Reflection of meteorological conditions by the sea surface (The effective temperatures of slicks and oil spots are dependent upon the amount and temperature of cloud cover. Oil spots generally appear cold at night when viewed under clear sky conditions. Under cloudy sky conditions they reflect in part the temperature of the clouds.)



- C. Problems of IRT operation under airborne conditions.
1. Naval Air Development Center experience with infrared radiometers indicates that the principal internal noise problem stems from aerodynamic flow past the optical system. Aircraft roll, pitch, banking, climbing and descending change the temperature of the optical system and cause variable signals.
  2. Collection of moisture on optics (This sometimes occurs if the aircraft descends from high altitude to low, warmer, more humid altitudes.)
- D. When the ocean is viewed at night with a vertical-looking IRT operating at low altitude and with negligible intervening atmospheric water (vapor, liquid or solid), the IRT provides a weighted-average temperature measurement of the upper few thousandths of an inch of the ocean provided the area viewed is free of slicks.
- E. "Bucket depth temperatures" should be calculable to within  $\pm 0.1C^{\circ}$  from night-time vertical IRT measurements provided air temperature, wind and humidity are known.
- F. Reports of IRT data should be standardized to include aircraft position as a function of time; cloud cover (altitude and percent coverage), air temperature, wind speed and direction, humidity, wave height, and aircraft altitude as functions of position; and synoptic weather and sea information from ships in the area surveyed.

#### RECOMMENDATIONS

1. Infrared mapping devices that can produce continuous thermal strip maps of the ocean should be used in conjunction with infrared radiation thermometers. The interpretation of wiggling recorder pen lines is made obvious in many cases if thermal pictures are available.
2. If it is desired to correlate IRT readings with bulk water temperatures, mapping flights should be conducted at night. "Noise" levels (from sun glitter) are lower at night; uncertainties due to surface reflection and due to surface heating from the action of the sun are eliminated. Night-time convective mixing permits the recording of IRT readings that are more indicative of bulk temperatures than recordings taken during periods of stability.



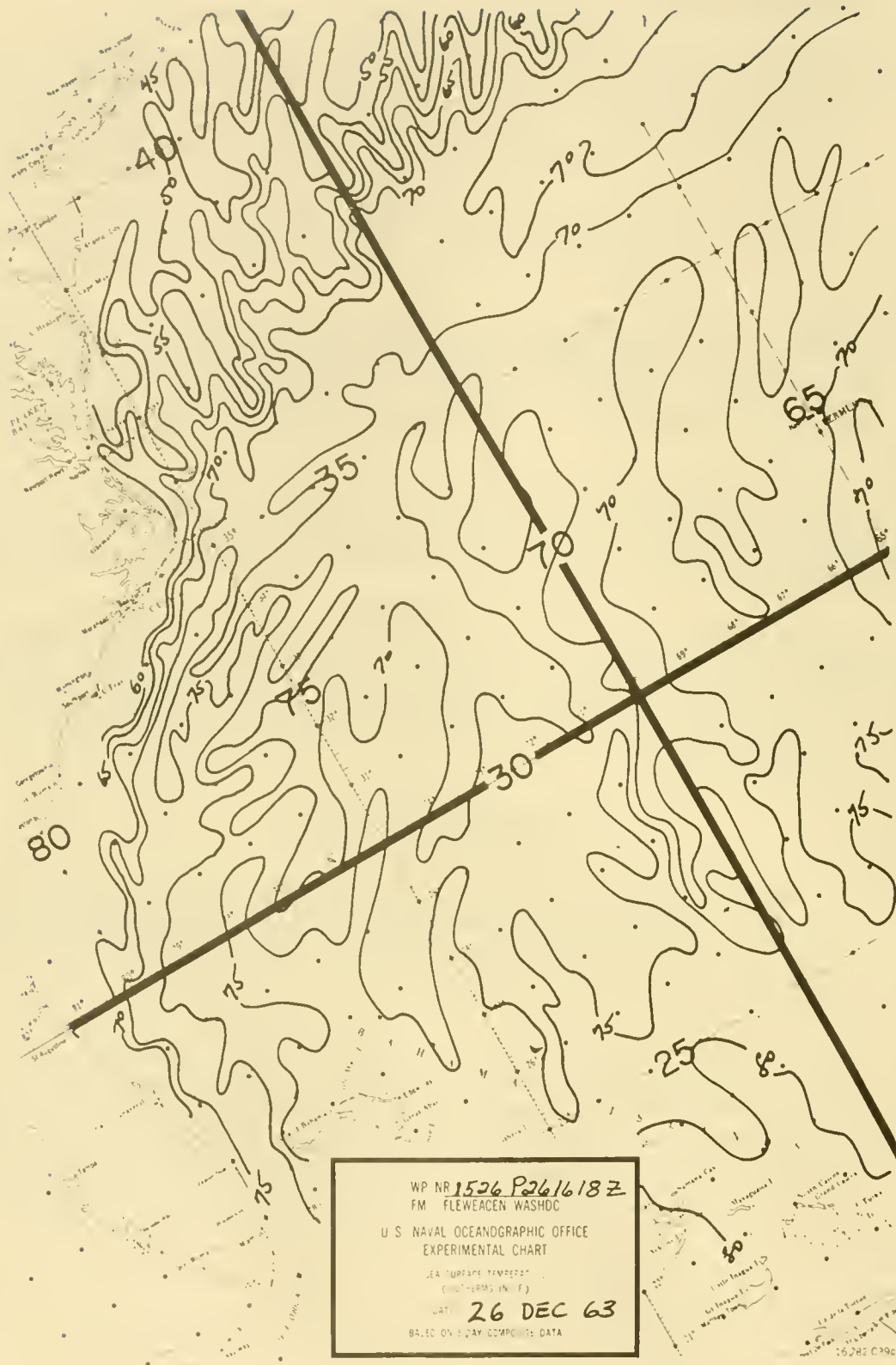

Figure 1. U.S. Naval Oceanographic Office Experimental Chart of Sea Surface Temperature. Isotherms in °F

## AIRBORNE RADIATION THERMOMETER ON THE PACIFIC COAST OF CANADA

by J. P. Tully, Pacific Oceanographic Group, Fisheries Research Board of Canada, Nanaimo, British Columbia, Canada

An oceanographic information service was initiated on a trial basis in 1959. As elsewhere, this depended on reports of sea surface temperature from transmitting ships and bathythermograms from Naval and research vessels. The data income was not adequate for any useful interpretation. Two approaches were taken to solve this dilemma (1).

By concentrated research in existing data (2), particularly from Ocean Station "P" (Lat  $50^{\circ}$ N, Long  $145^{\circ}$ W), models of the daily behaviour and seasonal growth and decay of the thermocline in the eastern subarctic Pacific were developed. These models revealed that during the heating season, the depth to the top of the seasonal thermocline was a function of wind history. During the cooling season it was a function of convection. During the heating season transient thermoclines occurred in the potentially isothermal layer above the seasonal thermocline. Their occurrence would be revealed by the signature of any continuous temperature recording device. Also such a device would reveal the occurrence of "fronts" where the thermocline turned up towards the surface (divergence areas) or where surface waters accumulated (convergence areas).

Some acquaintance with an Airborne Radiation Thermometer was acquired by borrowing Richardson's prototype equipment from Woods Hole Oceanographic Institution (3). It fulfilled all expectations. There were not adequate resources to provide a routine daily air patrol over the area for thermometry purposes alone. However, there were and are military air patrols covering the United States and Canadian areas. These could carry equipment if it was small enough, light enough, would work unattended and provided information of military significance. This required redesign of Richardson's equipment. No commercial manufacturer was interested in such a venture, therefore the Pacific Oceanographic Group developed a prototype (FRB-1) (4) which was flown during the heating season of 1961. On the basis of this experience (5, 6) construction of a more erudite model (FRB-2) was undertaken and is in the final stages of completion.

The equipment consists of a scanning head, a computer-recorder unit (Information Channel) and a Tactical Channel which has a visual indicator. These units are small and can be separated by 50 feet distance in the aircraft. The total weight is about 50 pounds. The equipment is turned on at the beginning of a flight. The information channel records apparent temperature on a suitable scale (there are nine scale brackets). The tactical display shows a green light when the rate of change of temperature is less than one Celsius degree per 10 miles, yellow when it is one degree per 5 to 10 miles, and red if the change is more rapid. This system indicates sudden changes (fronts) and erratic signature (transients).

To coordinate the flight track with the record position, numbers are dialed by the navigator onto the record.

The equipment has been built by the Pacific Oceanographic Group with some financial aid from the Royal Canadian Air Force and advice and assistance from Canadian Aviation Electric and Barnes Engineering. It is being flown by the RCAF. The records are interpreted by the Canadian Meteorological Service on the basis of know-how provided by the Pacific Oceanographic Group. The whole project is coordinated by the Oceanographic Services for Defence who provide oceanographic information for military and civil purposes.

Five units have been built. Two are for service use on the Atlantic coast, two on the Pacific coast and one for research assessment.

There are two phases of research assessment, the effect of the atmosphere on the radiation and the interpretation of apparent sea surface temperature into seawater structure. Neither research could be undertaken until quality equipment was available. Both researches are to be initiated this year.

Recently Mr. W. Bell of P.O.G. reviewed the available literature on atmospheric effects on infrared transmission through the atmosphere. He concluded that much of it is contradictory and no quantitative conclusions could be drawn to provide practical means of correcting ART records for height, pressure, moisture or haze. This research has been taken up by Dr. W. L. Godson of the Research Division of the Canadian Meteorological Service, who has considerable research background in this area. He proposes to review the literature again, discarding the doubtful and contradictory work. Then he proposes to conduct the necessary fundamental research to provide practical means of correcting the records to reveal the true temperature within limits of about  $0.1\text{C}^{\circ}$ . This is a meteorological problem and will be studied at Toronto.

To evaluate the relation of the sea surface temperature record to subsurface temperature and structure Dr. L. F. Giovando of the Pacific Oceanographic Group has designed a series of experiments.

He will mount the ART about 10 to 15 feet above the sea on a tower. He will place thermistor arrays in the water to observe the temperature, the structure and behaviour during heating and cooling periods. If the theory is correct, there should be a recognizable correlation.

During a cooling period or when there is convection the radiation temperature should agree well with the temperature in the mixed layer.

During a heating situation there should be a mixed layer due to wind or to surface evaporation. In either case the radiation temperature should represent the real sea surface temperature to the depth of the first transient thermocline. Such transients can only occur in a heating situation and because of the gust nature of the wind they must be local and irregular. Hence an irregular record betrays transients.

While these researches are in progress it is planned that the remaining three or four instruments will be used on routine patrol under limited conditions. The aircraft shall fly at constant height (900 to 1100 feet). There must be no haze or undercast. Previous experience here and elsewhere shows that usable records can be obtained under these conditions.

#### REFERENCES

1. Tully, J. P. MS 1961. Assessment of temperature structure in the eastern subarctic Pacific Ocean. Fish. Res. Bd. Canada, MS Rept. (Oceanog. & Limnol.) No. 103, 38 pp, Pac. Oceanog. Group, Nanaimo, B.C.
2. Tully, J. P., and L. F. Giovando. 1963. The seasonal thermocline in the eastern subarctic Pacific Ocean. Marine Distributions. The Royal Society of Canada. Spec. Publ. No. 5, Univ. Toronto Press.
3. Tully, J. P., M. Pirart and R. K. Lane. MS 1960. Airborne radiation thermometer Mark I. Feasibility tests. Fish. Res. Bd. Canada, MS Rept. (Oceanog. & Limnol.) No. 61, 13 pp, Pac. Oceanog. Group, Nanaimo, B. C.
4. Pirart, M. MS 1961. Airborne radiation thermometer (FRB-1). Fish. Res. Bd. Canada, MS Rept. (Oceanog. & Limnol.) No. 102, 20 pp, Pac. Oceanog. Group, Nanaimo, B. C.
5. Sowden, W. J. 1962. Report on the flying of an airborne radiation thermometer. Circ. 3778 TEC-445, Meteorological Branch, Dept. of Transport, Toronto, Canada.
6. Andersen, H. G. MS 1963. Some small considerations of the effect of cloud on an airborne radiation thermometer. Circular 1963-2, Fish. Res. Bd. Canada, Pac. Oceanog. Group, Nanaimo, B.C.

April 27, 1964



# CALIBRATION AND FIELD TEST OF IRT

by Takashi Ichiye and Noel B. Plutchak, Lamont Geological Observatory,  
Palisades, New York

## INTRODUCTION

Our interest in using IRT lies mostly in determining the fine structure of the surface water temperature concurrently with some field experiments of dye diffusion in the upper layer of the ocean. In such experiments, five to fifteen gallons of rhodamine "B" dye are dumped from a small boat and for several hours a light plane is used to take aerial photographs of dye patches. In many cases, dye patches indicate striations with spacings of furrows from several tens to hundreds of meters dimension. It is speculated that such striations are caused by cellular convective currents near the surface due either to turbulent structure of surface winds or internal waves (Ichiye, Iida and Plutchak, 1964; Ichiye, 1964). In any case, if there are cellular currents, surface water temperature may indicate alternative cold and warm bands as schematically indicated in Fig. 1. In order to determine such a fine structure in the surface temperature, IRT seems to be ideal if it has enough accuracy since the sensor of the IRT need not be immersed in the water and thus will not disturb the temperature pattern.

This report shows results of some preliminary experiments to determine the accuracy and operational capacity of the instrument. These results seem to indicate that there are so many factors influencing the readings that great precaution must be taken in order to obtain accurate data.

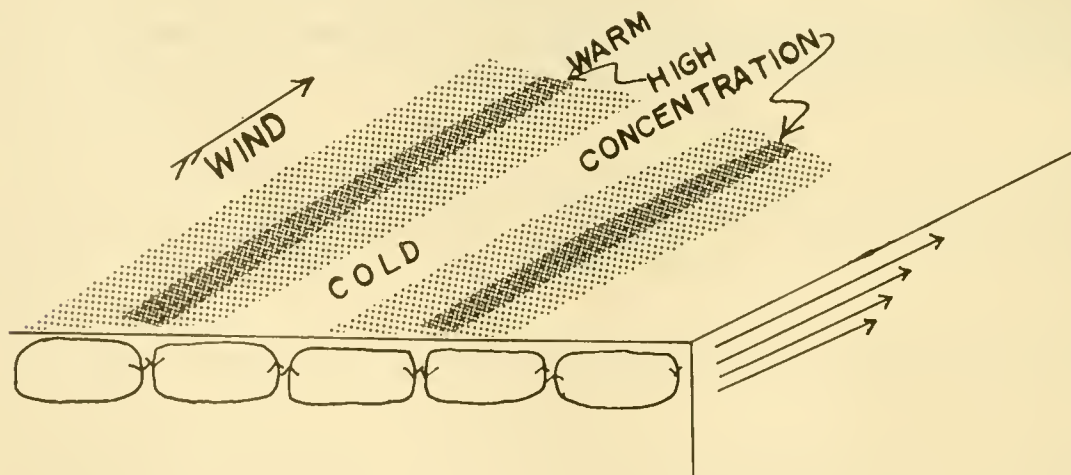

Figure 1. Schematic representation of alternative cold and warm bands thought to be caused by cellular convective currents



## CALIBRATION OF IRT

We are using the IRT Barnes Model IT-2. The first calibration was made indoors, using a water bath of 15 cm. diameter and 50 cm. depth agitated by a small motor-driven propeller. The room temperature was almost constant from  $75.8^{\circ}$  to  $77.0^{\circ}$ F. The IRT sensor was mounted on a tripod about one meter above the water surface. Water temperature was measured with a mercury thermometer recently calibrated by the Bureau of Standards. The comparison of the readings of IRT and water temperature measured by this thermometer for a range of water temperature from  $32.0^{\circ}$  to  $88.0^{\circ}$ F is shown in curves A and B of Figure 2. It is noted that the IRT readings are higher than the true temperature by almost  $2.0^{\circ}$ F for lower temperatures but the difference becomes very small as the water temperature becomes close to air temperature. This suggests that the air temperature between the sensor and the water has some influence on the IRT readings. The second calibration was made at the rooftop using the same set-up. The air temperature changes from  $31.5^{\circ}$  to  $33.0^{\circ}$ F. Curve C of Fig. 2 indicates that the effect of the air temperature caused IRT readings lower than the true values by  $4.0^{\circ}$ F in the range of  $90.0^{\circ}$  to  $100.0^{\circ}$ F and by  $2.0^{\circ}$ F in the range of  $60.0^{\circ}$  to  $80.0^{\circ}$ F and has  $1.0^{\circ}$  to  $2.0^{\circ}$ F in the range of  $40.0^{\circ}$  to  $50.0^{\circ}$ F water temperature. It was also recognized in this experiment that the wind gusts changed the readings of the IRT by  $1.0^{\circ}$  to  $2.0^{\circ}$ F.

In order to study further the effect of the air between the sensor and the water, a series of experiments were made by changing the vertical distance between the sensor and the water surface. A basin of 1.2 meters diameter was filled with hot water about 10 cm. deep. The water temperature was changed by melting snow. It was kept almost constant

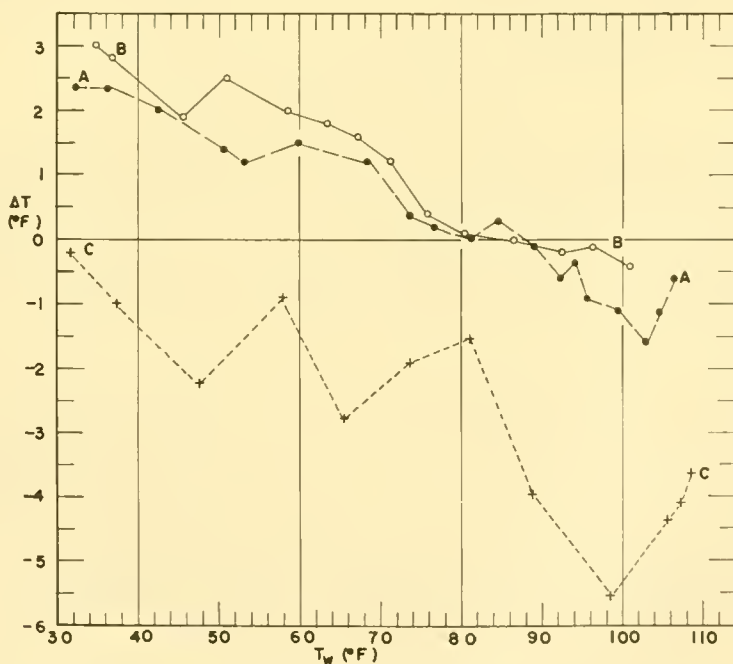

Figure 2. Calibration of IRT with water temperatures ranging from  $32.0^{\circ}$ F to  $88^{\circ}$ F; A and B, indoor tests; C, outdoor test

by agitating the water with the propeller mentioned above. The basin was put outside our three-storied Oceanography Building and the sensor was mounted at the rooftop, the third and second floor window, and on the tripod at ground level. The result is shown in Figure 3. Air temperature changed from 38.0°F for the rooftop mount to 33.0°F for the tripod mount. This figure indicates that the IRT readings are lower than the true values and the difference becomes large as the distance increases and as the water-air temperature difference increases. However, there is an indication that the effect of the distance might be diminished as the distance increases further.

The third series of experiments were made to determine the effect of angle of the sensor window from the vertical. The sensor was mounted on a rod at two meters above the water surface. Then the rod was rotated to about ten degrees from the horizontal while the sensor was always pointed at the same point on the water surface at the constant distance away. Each curve in Figure 4 represents a different situation, which includes both indoor and outdoor experiments. The outdoor experiments were made on a sunny day with snow on the ground and on an overcast day with snow falling. On each day the differences between the IRT and a mercury thermometer reading were varied according to the directions pointed by the sensor, that is, toward the building, the sky or the shade of a large tree. The effect of falling snow on the overcast day was so large in lowering the IRT readings that the effect of angles of the sensor seemed to be obscured. However, in all these situations angles of the sensor from the vertical less than 40° do not seriously influence the IRT readings.

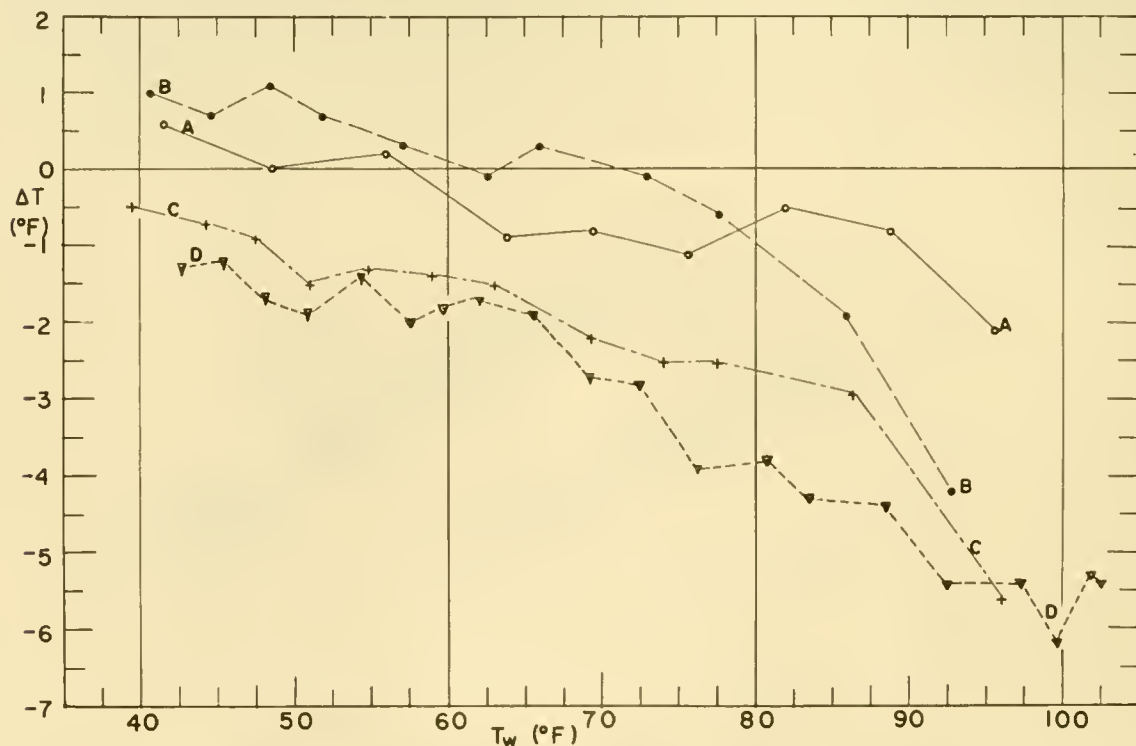

Figure 3. Results of tests with varying distance between IRT sensor and target; A - rooftop, B - third floor, C - second floor, D - ground level. See text for details

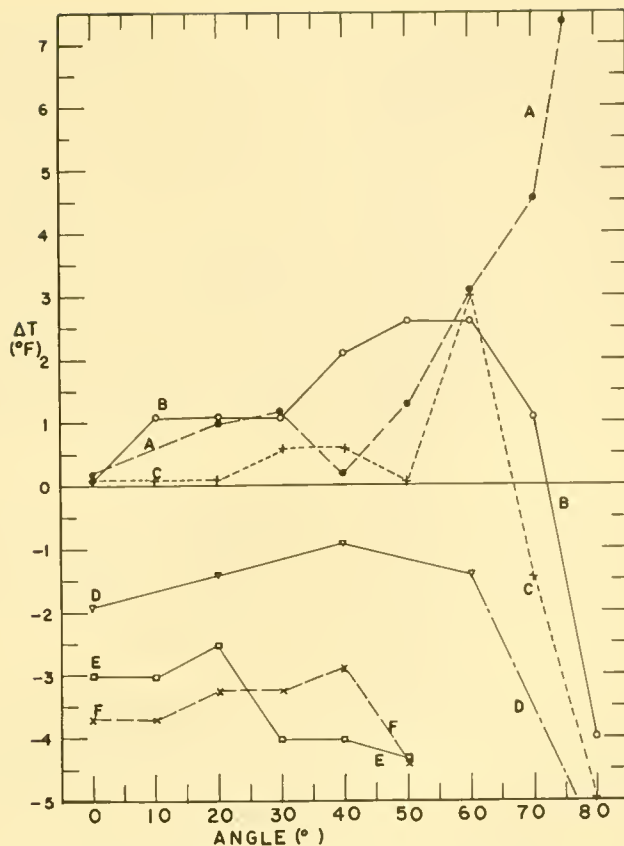

Figure 4. Results of tests with varying angle of view of IRT sensor. See text for details.

#### FIELD TESTS

The first field test was made on February 4, 1964, on a flight off Narragansett Bay by a Coast Guard Albatross used by Sandy Hook Marine Laboratory (Clark and Stone, 1964) with the intention of inter-calibrating our instrument with his. Our instrument was hand-held side by side with Clark's over a period of nearly two hours. The two instruments produced almost similar data except ours showed on degree (F) higher than his.

The second field test was done on a Cessna off Sandy Hook on February 12th. This test was scheduled to coincide with the course and passage time of the VEMA so that the IRT record might be compared with the record from the ship-borne sensor (thermistor). However, the ship left two hours earlier than the scheduled time and the rendezvous failed. Also, it turned out that the fluctuations in the power source of this kind of plane and the effect of wind on the instrument in such a small plane were so great that the records showed the temperature fluctuating across a range of  $10.0^{\circ}$  to  $15.0^{\circ}$ F. when the sensor was exposed to the air. Since the window in such a small plane is small, the effect of radiation from a body of a plane might be serious if we install the sensor inside the window. We should develop some device which may be used in a small plane to shield the effect of both wind and body radiation to the sensor.

The third field test was made on the occasion of dye diffusion experiments done in the middle of March off Panama City, Florida. On March 12th we mounted the instrument on a Navy tower 12 miles off shore. The height of the platform above the sea surface is about 100 feet. (Gaul, 1963) In this field test, two bits of evidence were found to demonstrate the usefulness of the IRT to detect a fine temperature structure. Figure 5 indicates the record of the IRT in the case of passage of a tide line. The BT data are also shown in this figure. The mercury thermometer readings show the increase of  $0.6^{\circ}\text{F}$  after the passage. The sharp rise in the record corresponds to this increase. Figure 6 shows the change of IRT readings in the wake of a boat with a draft of about 7 feet. On this day, air temperature is colder than the sea surface temperature and thus the temperature of the surface film seems to be much lower than the bucket temperature. This decrease of surface film temperature could not be detected by BT. However, the increase of IRT readings by about  $0.6^{\circ}\text{F}$  suggests the existence of such a film.

In concurrent use of the IRT with dye experiments, it was found that both the fluorescein dye and rhodamine "B" dye seem to raise the IRT readings. The actual traces of the IRT on board a ship and on the stage are shown in Figure 7. The former indicates the rise of IRT readings at the edge of the rhodamine "B" dye patch.

It is interesting that the subsequent main part of the dye patch did not show any change in the IRT record although the patch was clearly visible on board the ship and from an airplane. This is consistent with other observations that dye is close to the surface of the leading edge of dye patches but is found deeper in the trailing part (Ichiye, 1964). The latter shows also a jump of about  $1.0$  to  $2.0^{\circ}\text{F}$  when the dye patch was passing. Later laboratory experiment indicates that the rhodamine "B" dye increased the IRT readings by  $1.5^{\circ}\text{F}$  immediately when the powdered dye was added and by  $2.5^{\circ}\text{F}$  after the surface film was formed in water of  $66.0^{\circ}\text{F}$ .

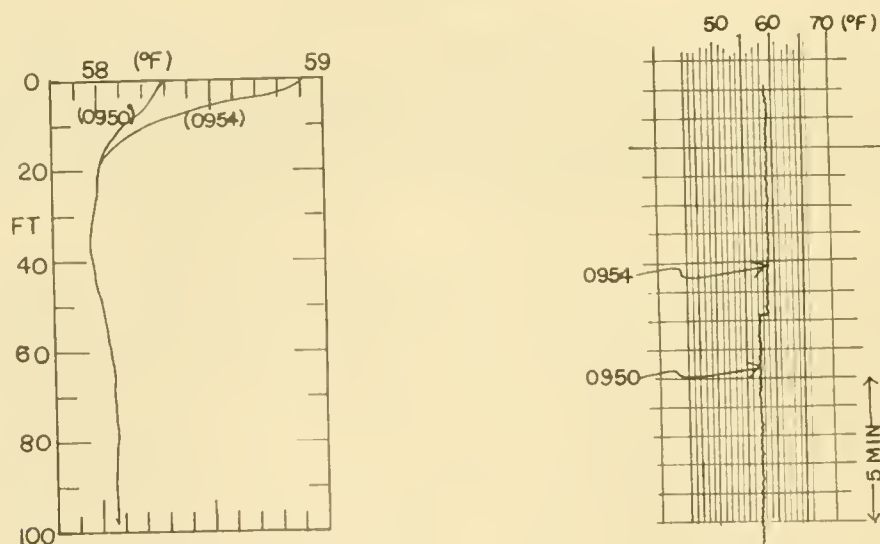

Figure 5. Effect of a tide line passing IRT fixed on Panama City Tower. Bathythermogram shown at left for same time and place



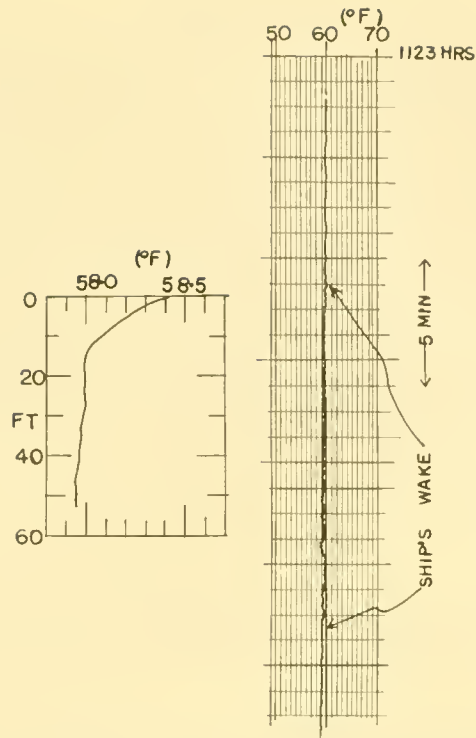

Figure 6. Effect of a ship passing IRT fixed on Panama City Tower  
Bathythermogram shown at left

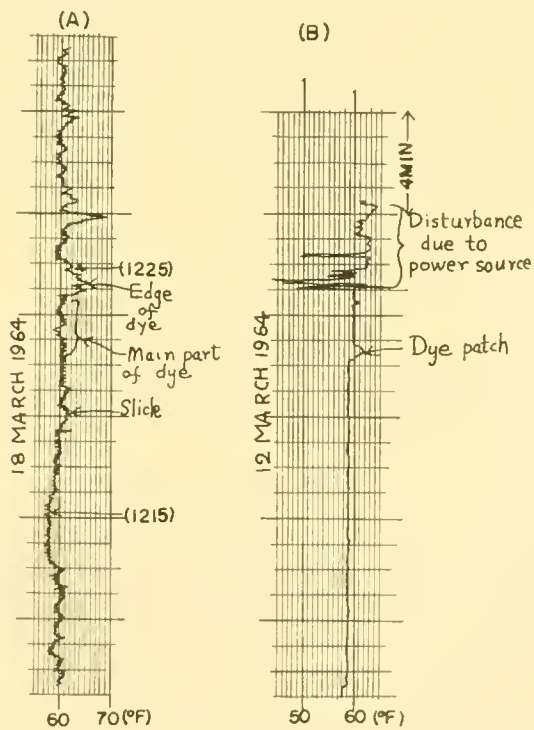

Figure 7. Effect of dye at surface on IRT readings. See text for details

## DISCUSSION

It was very surprising and rather annoying to us that the differences between the IRT and mercury thermometer readings  $\Delta T$  were so large both in indoor and outdoor calibrations, as indicated in Figures 2 and 3. These differences are much larger than those reported by other studies (Pirart, 1961; Richardson and Wilkins, 1957) although the calibrations in these studies were made in the situation of much smaller air-water temperature differences than the extreme cases of the present calibrations. The results of Figure 2 clearly indicate that the IRT at the constant distance from the water surface gives higher readings than mercury thermometers when the air is warmer than the water and vice versa. Those of Figure 3 indicate that these differences between IRT and mercury thermometers increase with the air path between the sensor and the water if the air-water temperature differences are constant.

The relation between the absolute temperatures of the ocean, and atmosphere  $T_w$  and  $T_a$  and those obtained by the IRT readings  $T_i$  is expressed approximately by

$$T_i^4 = Et T_w^4 + (1 - Et) T_a^4$$

where  $E$  is emissivity of the ocean;  $t$  is the transmissivity of the atmosphere (Frank, 1964).  $E$  is almost constant and equals to 0.98 but  $t$  is dependent on the radiative characteristics of the air column between the sensor and the sea surface. In ordinary meteorological situations without actual precipitations, the most important factor affecting  $t$  is the amount of water vapor in the air path. The values of  $t$  in percentage as a function of the precipitable water in cm were determined by Yates and Taylor (1960). However, the calculation based on these results gives much smaller values of  $\Delta T$  than those in Figures 2 and 3. Instead,  $t_i$  is determined from equation (1) by using the observed values of  $T_i$  (with the IRT),  $T_w$  (with the mercury thermometer) and  $T_a$ . For the averaged values of  $T_z$  of the curves C and D of Figure 3, the computed values of  $t$  are as follows:

$t$ (%)	95, 93, 94, 92, 92	for $T_a = 30^\circ\text{F}$
$T_w$ ( $^\circ\text{F}$ )	60, 70, 80, 90, 100	

For the change of  $T_a$  from  $33^\circ\text{F}$  to  $38^\circ\text{F}$ , as observed in this calibration experiment, the variation of  $t$  is 1% at the most. The value of  $t$  estimated from the results of Yates and Taylor (1960) equals to 99.8% for the saturated air of 8.5 m deep with temperature  $36^\circ\text{F}$ . This estimation is based on the assumption that the water vapor is in a gaseous form. However, evidently there was a layer of steam close to the water surface in the outdoor experiment of Figure 3, particularly when the water temperature was higher than  $80^\circ\text{F}$ . When water-droplet radius is near the wave length of radiation, Mie-scattering becomes effective and the absorption is much larger than in the gaseous form of water vapor (McDonald, 1960). Therefore, the large values of  $t$  obtained from the experiments seem to be due to this effect.

Since sea steam which is much thinner than sea fog is a rather common phenomenon, particularly in cold seasons (Von Arx, 1962), caution should be taken for the use of IRT in such occasions. Also, accurate measurements of the transmissivity  $t$  in the presence of sea fog or sea steam will give us information on congregate structures of water droplets.

It is notable that the effect of air temperature is negligible when the air is much warmer than the water as indicated in later calibration (Aug. 6, 1964), in which the entire experimental set-up was the same as in that of Figure 3. The results indicate that the  $\Delta T$  ( $=T_i - T_w$ ) is  $-0.4^\circ$  to  $0.9^\circ$  F for the range of  $T_w$  from  $51^\circ$  to  $78^\circ$  F with the air temperature  $82^\circ$  to  $86^\circ$  F at the air path of 9.9 meters. There is almost no correlation between the values of  $\Delta T$  and  $T_w$  and thus the differences  $\Delta T$  seem to be caused by other effects than those of water vapor. Since in this experiment the air temperature was higher than the water temperature, the air layer close to the water surface was stable and evaporation was also very small.

### CONCLUSIONS

- (1) Effect of the temperature of the air column between the sensor and the water becomes important when the air-sea temperature difference exceeds  $10.0^\circ$  F.
- (2) The distance between the sensor and the water also influences the IRT readings.
- (3) The effect of angle of the sensor becomes serious when the angle exceeds  $40^\circ$ .
- (4) The snow or rain might substantially affect the IRT values.
- (5) The IRT is useful to detect tide lines or ship's wake.
- (6) The rhodamine "B" or fluorescein dye causes an increase in IRT readings.

### ACKNOWLEDGMENT

The present work is supported jointly by Contract Nonr 266(48) with the Office of Naval Research and by Contract AT(30-1)2663 with the Atomic Energy Commission.

### REFERENCES

Clark, J. and R. Stone, 1964: The use of the infrared thermometer in routine coastal survey--a summary. Workshop Contribution.

Frank, J. L., 1964: The accuracy of airborne infrared thermometry. Workshop Contribution.

Gaul, R.D., 1963: Status of environmental research off Panama City, Florida. Technical paper A and M College of Texas, Project 286 (D), Ref. 63-2T. p. 82

- Ichiye, T., 1964: On a dye diffusion experiment off Long Island. Tech. Report CU-9-64 to the Office of Naval Research and CU-10-64 to the Atomic Energy Commission, pp. 19
- Ichiye, T., H. Iida and N. B. Plutchak; 1964: Analysis of diffusion of dye patches in the ocean, Tech. Report CU-8-64 to the Office of Naval Research, pp. 16
- McDonald, J. E., 1960: Absorption of atmospheric radiation by water films and water clouds, J. Meteorol. Vol. 17, 232-238
- Pirart, M., 1961: Airborne radiation thermometer (FR B-1). Manuscript Report Series (Oceanog. and Limnol.) No. 102, Fish. Research Board of Canada, p. 12
- Richardson, W. S. and C. H. Wilkins, 1957, An airborne radiation thermometer, Deep-Sea Res. 5, 62-71
- Von Arx, W. S., 1962: An Introduction to Physical Oceanography, p. 422, Addison-Wesley Co.
- Yates, H. W. and J. H. Taylor, 1960: Infrared transmission of the atmosphere, Naval Research Laboratory Report No. 5453



# COMMENTS ON THE VALIDITY OF SEA SURFACE TEMPERATURES AS MEASURED WITH THE BARNES INFRARED THERMOMETER\*

by Robert A. Ragotzkie, Department of Meteorology, University of Wisconsin, Madison, Wisconsin

The Barnes IT-1 and IT-2 (Infrared Thermometer) are being used extensively for surveying the surface temperature of lakes in Wisconsin and central Canada north to the Arctic coast and for mapping surface temperature of Lakes Michigan and Superior. In the course of these airborne measurements, a number of field checks on the validity of the IT results have been made. Airborne measurements were made from either a U.S. Navy P2V or from a Cessna 195 floatplane at an altitude of 1000 feet or less. Surface checks were made by measuring the water temperature in the upper 5 cm layer with a thermistor thermometer which had been calibrated against a certified mercury thermometer.

These measurements were made either from a small boat directly under the flight path of the aircraft or from the float plane which landed immediately after the airborne measurement was complete. On Lake Superior checks have been obtained from University of Wisconsin geophysicists aboard Coast Guard vessels. A calibrated thermistor thermometer supplied by us was used, and measurements were made at the time of fly-over by our aircraft. Results were transmitted by radio and compared to the airborne measurement immediately. The points below 20°C were obtained on Canadian Lakes and those above 20°C on Wisconsin Lakes. Table 1 gives additional paired data which are not included in figure 1.

In the paired data given in figure 1 the airborne measurements are in all cases either equal to or higher than the in situ measurements with a tendency for the differences to be larger as the roughness of the water surface decreases. However, later measurements (see table) indicate that airborne measurements can be either higher or lower than in situ measurements. For example the 1 June 1964 data were all collected between 1545 and 1645 CDT, and all but one of the airborne measurements indicated a lower surface temperature. Water temperatures were measured at the surface (5 cm) and at 25 cm intervals down to 50 or 100 cm. On Lake Koshkonong where the airborne temperature was slightly higher, the water surface was nearly smooth and the top meter of water was thermally stratified indicating surface heating was occurring. In the other three cases for this date the airborne measurement was low and the top layer of water showed a slight inverse temperature stratification indicating surface cooling probably due to increased evaporation from wind action. On Lake Superior the differences were in both directions, but there is insufficient surface data to attribute the discrepancies to any particular factors.

It is clear that the water temperature obtained from an airborne IT may be either higher or lower than that obtained in situ. Even disregarding atmospheric absorption or emission errors and small reflection errors, it is clear that the results of infrared

\* This research was sponsored by the Geography Branch of the United States Office of Naval Research under contract No. Nonr 1202(07).

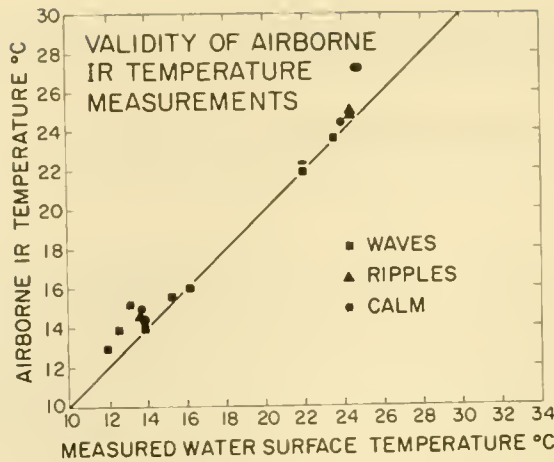

Figure 1. Validity of Airborne Infrared Temperature Measurements

measurements must be interpreted with caution if the actual temperature of the upper meter or two of water is desired. However from the point of view of the meteorologist who is concerned with problems of heat and moisture flux through the true surface of the water, infrared measurements are probably superior to *in situ* surface layer measurements. Air-water interface processes depend on temperature and vapor pressure gradients between the true water surface and the overlying air, and the infrared thermometer very likely comes closer to indicating the effective surface temperature than any other means.

Much more field checking needs to be done. It is especially important when comparisons between the two methods are made, that detailed observations be made of the conditions of the sea surface, the wind, the thermal stratification of the upper layer of water and the temperature and humidity of the air above the surface. Sky conditions and sun angle may also be important in establishing the radiation input. Only with complete supporting data will it be possible to separate the surface heating and cooling cases and assign some level of importance to the various meteorological factors. With the present state of our knowledge it is not yet possible by flying over a body of water to determine with any degree of reliability whether the IT will yield a higher or lower temperature than an *in situ* measurement of the surface layer, nor will a single check on a particular day be applicable to other parts of a large body of water or to other lakes in the same region on that day. Hopefully this situation can be improved by continued and more careful field observations.

TABLE 1.

Validity check on airborne Barnes Infrared Thermometer  
measurements, 1964

<u>Lake*</u>	<u>Date</u>	<u>Airborne (°C)</u>		<u>Water (°C)</u>	<u>Water Surface condition</u>
Mendota	20 April	7.5-8.0		6.3-6.4	actively forming wind waves,
Mendota	1 June	17.5	5cm	18.77	wind waves
			25	18.77	6-10", no white caps
			50	18.77	
			75	18.78	
			100	18.78	
Waubesa	1 June	18.5	5cm	20.45	wind waves 4-6",
			25	20.48	foam lines
			50	20.47	
Kegonsa	1 June	19.5	5cm	20.35	wind waves 4-8",
			25	20.36	foam lines
			50	20.38	
			75	20.38	
			100	20.38	
Koshkonong	1 June	19.8	5cm	19.76	old wave 2-3", sur-
			25	19.74	face appeared smooth
			50	19.57	from above
			75	19.51	
			100	19.40	
Superior	26 July	17.0		18.3	wind waves, no white caps
	26 July	12.0		12.71	wind waves, no white caps
	27 July	18.1		16.5	

\* All lakes except Superior near Madison, Wisconsin. Most data were obtained after the Workshop and forwarded for inclusion in the report.

## COMMENTS RELATIVE TO INFRARED RADIATION THERMOMETER WORKSHOP

by John W. Reintjes, U.S. Bureau of Commercial Fisheries,  
Beaufort, North Carolina

Determination of sea surface temperatures with an airborne infrared radiation thermometer was initiated at the U. S. Bureau of Commercial Fisheries Biological Laboratory, Beaufort, N. C., in August 1963. The area between Cape Hatteras and Cape Fear, North Carolina, out to the edge of the Continental Shelf, was the accepted responsibility of the laboratory as part of a cooperative program.

An infrared radiation thermometer (Barnes Engineering IT-2), a strip recorder (Varian G-11A), and an inverter (ATR, Model RSF) were purchased. A test flight in a U.S. Marine Corps Fairchild C-119 was unsatisfactory because of excessive fluctuation of the read-out directly from the dial or by the recording stylus. The sensing head was mounted vertically in the flare tube with a sponge rubber adapter or hand-held out the rear observation hatch. Neither location gave acceptable results. Test operations on the ground indicated sonic interference from the aircraft.

A test flight was made in a U. S. Coast Guard Grumman "Albatross" (UF2G) on October 14, 1963 to compare the results of our instrument (IT-2) with an IT-1 from Sandy Hook Marine Laboratory. Side by side operation showed the IT-2 unable to cope with air stream conditions that permitted satisfactory operation of the IT-1. The instrument was bench checked and then ground checked in a Douglas DC-3 aircraft. These checks demonstrated the fluctuations were due to air stream interference in the sensing head. Apparently this is an intrinsic condition in the earlier models of the IT-2 with an unsealed cavity. Successful in-flight operation required installation free of excessive turbulence or air stream interference.

Successful operational flights were completed on November 27, December 20, 1963; January 20, March 17, and April 17, 1964 in U. S. Coast Guard UF2G "Albatross". On all flights the sensing head was mounted on a bracket on the frame of the rear left hatch inside the fuselage. The detector was directed at the sea surface from 30° to 45° from normal. Needle and recording stylus fluctuated less than 1°C. during normal flight attitudes. Occasionally, during skidding turns, variations, apparently due to turbulence, would exceed 2°. A temporary baffle along the leading edge of the hatch opening shielded the head from air stream interference and improved the trace. Although this installation is not wholly satisfactory, it is expedient unless structural modification and a permanent mounting are made in the aircraft. We have considered a contoured hatch or shield with a small opening for sighting the detector. At the present time, drift bottles and seabed drifters are thrown overboard from the hatchway and as yet we have not met the requirements for an open but sheltered port.

Radio communication with Diamond Shoals and Frying Pan Shoals Lightships was established during all flights for surface water temperatures while the aircraft was flying over or in sight [range] of the vessels. In general the temperatures reported by the vessels



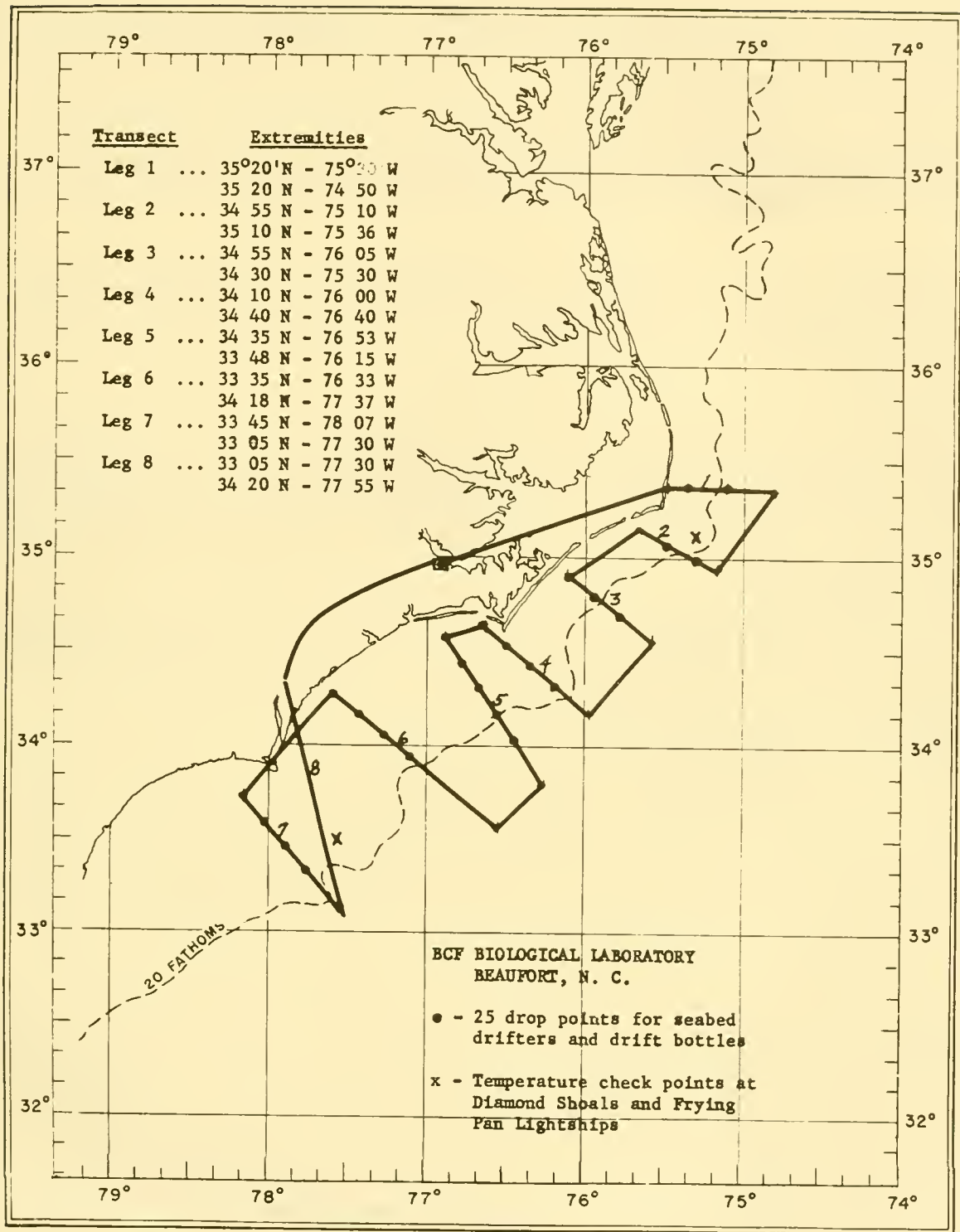

Figure 1. The proposed track for temperature survey flights over the Continental Shelf from Cape Hatteras to Cape Fear, North Carolina

were 1° to 3° warmer than the infrared radiometer. These lightships are in areas of great turbulence and near boundaries of maximum temperature gradients, therefore the significance of this disagreement is not known.

Surface water temperature checks were made on December 20, 1963 and April 17, 1964 with the aircraft circling the laboratory boat for simultaneous temperature data. The results showed almost identical readings as follows:

<u>Date</u>	<u>Time</u>	<u>Bucket Temp. °C.</u>	<u>IT-2 Temp. °C.</u>	<u>Air Temp. °C.</u>
December 20, 1963	1140	8.6 - 8.9	8.5	ca. 5.0
April 17, 1964	1215	20.7 - 20.8	20.5	ca. 20.0

It should be noted that the air temperature was not essentially different from the water temperatures. The lightships, on the other hand, were in deeper water near the inshore confluence of the Gulf Stream where the air-sea temperature differences were greater. During all flights the air temperatures were lower than the water temperatures recorded in the vicinity of the lightships.

In-flight temperature checks with a bucket of water and a mercury thermometer were made during all flights. The water temperature and air temperature, in the aircraft, were approximately the same. These checks were made to ascertain the normal operation of the instrument and recorder rather than for calibration.

We have not conducted field studies of the effects of wind, spray, fog, or reflected sunlight on the recorder temperature. In-flight observations over an area presumed to be relatively constant showed no obvious temperature changes with reflected sunlight, increased white caps and spray from increased wind velocity, or changes in bolometer angle from 30° to 60° normal. Also, changes in flight altitude from 300 to 1,500 feet caused no apparent change. All of these conclusions are based on observations without a known reference.

The limits of accuracy of our instrument as we operate it have been within .5°C. of the temperature of water dipped from the sea surface with a bucket and read within 30 seconds with a mercury thermometer or thermistor. In our opinion this accuracy is more than adequate for the turbulent shallow waters of the area we are surveying. For example, in April 1964 the sea temperature changed 10°C. in less than 5 miles at the inner boundary of the Gulf Stream. The continual interaction of coastal turbulence from Capes Hatteras and Fear and the Gulf Stream keep the shelf waters of our section of the coast in such a state that any attempt at greater accuracy than ±.5°C. probably is meaningless. Changes with time are a far greater concern. For all we know, Gulf Stream waters may invade within the 10 fathom contour and recede in a few days. Conversely, cooler or warmer water from meteorological conditions may dominate much of the shallow shelf of the region for relatively short periods.

Prop noise and electronic interference may give an irregular trace but do not seem to affect the accuracy. Even with a straight line trace, there is no reason to expect a greater agreement of IT and bucket temperature than  $.5^{\circ}\text{C}$ .

From our limited experience, we believe the IT readings are essentially the surface water temperatures for the air/sea temperature range and conditions under which we operated during the December 1963 and April 1964 flights. We have no other direct evidence to present.

Flights used for contiguous coverage should be on the same day or within a few days of each other. However, the necessity of obtaining clearance in certain restricted areas may make this difficult or impossible to achieve. We had to alter our flight path slightly for this reason.

Before we rely on monthly flights, the changes that occur in shorter periods should be investigated. Particularly during certain months of known instability and in areas as the North Carolina Cape - Gulf Stream confluence. We are not able to do this under present manpower conditions.

We suggest temperature be shown to the whole degree C. [or K.] by 1 degree intervals on a grid along the flight path. No attempt to interpret the data by isothermal lines should be done with initial results. Let the recipients do their own interpretation.

The power supply seems marginal and barely adequate. A recording device for machine interpretation would be preferred. If strip recorders are used, then the number and frequency of in-flight time or position and bucket temperatures should be standardized.

# INFRARED RADIATION THERMOMETER — AN EVALUATION

by Robert C. Barnes, Virginia Institute of Marine Science,  
Gloucester Point, Virginia

## INTRODUCTION

The infrared radiation thermometer (IRT) has been employed at the Virginia Institute of Marine Science during the past year in a variety of studies using three major techniques: (a) airborne surveys; (b) shipboard surveys; and (c) fixed platform mounting.

Although all of the work accomplished to date has been considered "experimental," it is felt that a quantity of useful and presumably valid data has been collected and that significant progress has been made toward arriving at an "operational" method of investigation.

The following report briefly describes the laboratory IRT programs, methods of operation, instrumentation, specific problems encountered, and an estimate of validity of the IRT technique as applied to thermal measurement of water masses.

## SUMMARY OF IRT PROGRAMS

### Mid-Atlantic Continental Shelf Study (MACONS)

In MACONS studies, sea-surface temperatures of Atlantic-shelf waters between Cape Henlopen, Delaware, and Cape Hatteras, North Carolina, are being surveyed monthly as one phase of a study of ocean currents and weather conditions by the Institute in co-operation with the Navy Weather Research Facility, Norfolk, Virginia. The area involved is approximately 10,000 square miles and extends eastward to the 100-fathom line. The first flight took place in June 1963 and the survey will be continued through September 1964.

Shelf measurements are obtained with the thermometer sensing head mounted in the camera hatch of a Navy P2V patrol aircraft. Electronic instruments within the aircraft measure the wind velocity and direction in order to estimate the sea-state along the flight line. During the survey the aircraft maintains an altitude of 250 feet.

### Chesapeake Bay Airborne Survey

Monthly flights of southern Chesapeake Bay waters were instituted in July 1963. This program was initially begun in order to evaluate aerial application of the infrared thermometer and has been largely exploratory to date. Five flights were made in 1963 covering Virginia waters of Chesapeake Bay and its major tributaries. The October flight was extended to include waters of central Chesapeake Bay and the Patuxent River in co-operation with a program of the Chesapeake Biological Laboratory, Solomons, Maryland.



Bay flights are made at an altitude of 600 feet (higher near populated areas) in a Cessna 172 aircraft. The sensing head is mounted in the luggage compartment and views the sea-surface through an observation hole in the deck. Air temperature is measured before and after each survey and sea state is estimated along the flight track.

The IRT has been found to be particularly well-suited for airborne surveys of large estuarine systems. As temperature changes in such restricted, shallow waters are often great and rapid at certain periods of the year, virtually synoptic coverage over a wide area by the IRT has several distinct advantages to both the physical oceanographer and biologist over conventional ships surveys even though only one parameter can be measured.

Longitudinal gradients in the estuaries are often readily apparent, and shoal-channel boundaries have been sharply defined in transverse sections taken during certain periods of the year.

Tidal influences at times cause interesting patterns at estuary mouths, and these may, with careful studies in the future, be delineated throughout an estuarine system by IRT techniques.

An expanded program for study of all Chesapeake Bay waters is planned. Of special interest will be rates of change over short periods and attempts to correlate changing temperature patterns with measured tidal currents.

#### Ship and Stationary Platform Studies

In addition to airborne surveys, the IRT has been used to study the thermal pattern and mixing characteristics of an effluent at the Virginia Electric and Power Company plant on the lower York River. With the sensing head mounted on the antenna staff of a motor launch, a series of traverses across the area yielded a detailed picture of thermal conditions. Further studies over several tidal cycles are in the planning stage.

In order to record surface temperature changes through time at a fixed point and to study the effects of weather conditions (i.e. rain, fog, etc.) on accuracy of measurements of the IRT, the instrument was mounted for one week on the tender's house of the York River Bridge at Yorktown. Readings were compared with those taken with an Induction Conductivity Temperature Indicator (ICTI) mounted in the support caisson below the tender's house. Further checks were achieved by bucket sampling of surface water. Bathythermograph lowerings delineated the subsurface thermal structure and a current meter measured tidal flow. Surface winds and relative humidity were recorded and wave height was estimated.

#### INSTRUMENTATION

The Institute has employed a Barnes Model IT-1 infrared thermometer in investigations. In February 1964 the company loaned a Model IT-2 for evaluation, but little actual surveying was accomplished due to equipment malfunctions.

Three recorders have been employed with the IT-1. These are:

- (1) Bausch and Lomb Model V. O. M. 5
- (2) Sargent Model (SR) S-72180
- (3) Nesco Model JY110

If size and weight are not to be considered, the Sargent is preferable to the B&L because of greater accuracy ( $1/4^{\circ}/00$  vs.  $1/2^{\circ}/00$ ), wider chart (10 inches vs. 5 inches), noise filter controls, and a range attenuation feature that is especially useful in recording IRT measurements. The greater bulk and weight of the Sargent (45 lb vs. 16 lb.), however, make it difficult to transport and mount in an aircraft. The B&L V. O. M. 5 is considered a relatively accurate and dependable recorder for IRT work. The Nesco instrument has been less promising than the other recorders in Institute operations.

Power sources vary with usage. During tests on the York River bridge, housepower was used for the IRT and strip-chart recorder. On ships and during bay surveys in the Cessna, two 12-volt storage batteries connected in series are utilized to run the IRT and recorder. An inverter converts the DC battery output to about 128 volts AC. A variable rheostat and on-line voltmeter permit a regulated power supply of 115 v. AC. A meter monitors frequency. A spare inverter is carried on flights as it is recommended by the manufacturer that these units not be used continuously for more than five hour periods.

On shelf flights 28-volt plane power (supplied directly to the inverter) is used instead of batteries.

The biggest single problem encountered with power supplies is the frequency variability when using batteries or a 28-volt generator with an inexpensive inverter. A sharply defined frequency is rarely obtained. The frequency is normally about 62 cycles per second and this may vary as much as 2 cps over a short period, although in general the peak remains at  $\pm$  one cycle. The effect of this on accuracy of readings and recordings has not been defined with certainty, but no large discrepancies were noted during limited laboratory tests.

It has been found that new well-charged batteries serve as an adequate power source for continuous IRT and recorder operating periods of longer than 10 hours, but no endurance trials have been run to specifically test maximum life expectancy.

The following is a list of power supply components used in VIMS operations:

BATTERIES (2) — 12-volt heavy duty automotive storage

INVERTER — ATR DC-AC, type 28U model RSF, input 28 volt DC (recommended, however, for 24 v systems), output wattage int. 125, cont. 100, AC output variable by four steps.

VOLTAGE REGULATOR — "Powerstat" variable transformer #20  
Superior, 646306, Model 375 BU

VOLTAGE INDICATOR — Simpson voltmeter (0-150 v)

FREQUENCY INDICATOR — JBT frequency meter, Model 34-FHXX-Z  
(100-130 v)

### RECORDER CALIBRATION

No attempt has been made by the writer to match up actual temperatures to strip-chart scales (40° equals 40 on a chart, 80° equals 80, etc.) as has been done by other workers. Instead, absolute chart paper scales have been disregarded completely in an effort to achieve the greatest possible chart width per degree of temperature. In order to accomplish this, the first step was to estimate the maximum and minimum surface temperatures expected on a given survey date. The recorder was then calibrated so that these values fell near the edges of the chart — leaving enough scale width at each margin to allow for a few degrees error in the original estimations.

As an example let us assume that on a shelf flight in February the expected minimum temperature would be near freezing along the shoreline and the maximum might be 70 degrees in the Gulf Stream Front near Cape Hatteras. The IRT and recorder would then be set up in the laboratory prior to the flight and two water baths prepared, one at 75 degrees and the second an ice mush. A proper millivolt setting is selected on the recorder and the recorder adjust screw on the IRT console turned as the sensing head is alternately aimed at the warm and cold baths until the recorder pen makes a full sweep of the chart.

The laboratory accuracy check is accomplished by placing a magnetic stirrer and reference thermometer in the ice mush. The water bath should be small enough so that the water is well mixed by the stirrer, but not roiled. Thermometer bulb should not touch the sides of the bath. When the ice has melted and the water begins to warm up, readings are taken at frequent intervals on the reference thermometer and the temperatures written on the chart paper opposite corresponding positions on the pen trace.

The test can be accelerated by raising the temperature in steps (i.e., pouring amounts of hot water into the bath, allowing mixing, marking temperature, adding more hot water, etc.) Once the readings are completed, a small amount of chart should be torn from the spool and the positions of the two extreme readings marked on it. As scale accuracy tends to break down at very low temperatures, it is advisable to use a temperature near 40-45 degrees as the lower reference point. By use of dividers a scale is then constructed on the chart paper. Positions of the other readings taken during calibration are then matched to the scale to verify accuracy.

The calibration is rechecked periodically during flights by a water bath and reference thermometer. As a final check during flights, console dial readings are taken at intervals



and transferred to the chart recording. These are later checked against the laboratory scale.

Surface readings are simultaneously collected from the Institute research vessel and the Chesapeake Lightship. The laboratory scale is compared to these field readings and adjusted if necessary.

During analysis of data, a mean is marked along the pen trace and degree lines inked in where necessary to show temperature fluctuations.

The above method of chart calibration is especially useful in the warmer months when gradients are low and the total temperature range small.

### INSTRUMENT PROBLEMS

The Model IT-1 purchased by the Virginia Institute of Marine Science was initially found to possess a significant reading error. A laboratory calibration indicated that the error was linear with the greatest discrepancy in the low temperature range (IRT 31°F - reference thermometer 38°F) and only a small error at higher temperatures (94-1/2°F - 95°F). Moreover, the needle on the readout dial was extremely "nervous" and hunted over a range of more than eight degrees. Factory modifications dampened the needle to a hunting range of not more than 2°F. Subsequent laboratory tests following calibration disclosed a small reading error of about two degrees at low temperatures still present but none in the higher ranges.

During calibration of the chart recorder, it was found that in order to get the desired attenuation (maximum chart width per degree) over small temperature ranges a low millivolt setting on the recorder (25 mv or less) and a high millivolt output from the IRT were necessary, but whenever the output was adjusted to give the proposed range, the recorder pen went off scale. The problem was solved by connecting two potentiometers and a 1-1/2-volt battery into the IRT-recorder cable. This gave the recorder a greatly extended zero and permitted the pen to be brought back on scale. Using this circuitry, it has been possible to develop a scale of one degree per inch on the 10 inch Sargent recorder, permitting extremely accurate reading of a trace.

The convenient attenuator built into the Sargent recorder permits "fine-tuning" scale adjustments in addition to the recorder adjust screw on the IRT console. By careful adjustment a chart can be calibrated so that one division equals exactly one degree, four divisions equal exactly one degree, etc. — greatly simplifying data reduction.

During early surveys it was noted that the console needle was nervous in flight although quiet during lab tests. The data from one entire flight, in fact, was useless because of the wild needle swings and extremely inaccurate readings. The problem was traced to slipstream currents disturbing the sensing head. The effect was particularly pronounced in cold weather when the frigid air blast likely had a cooling effect on the reference cavity. The sensing head was subsequently mounted two feet above the aircraft deck on an angle iron "T" and no further trouble was encountered.



In March 1964, Barnes Engineering Company forwarded a Model IT-2 to the writer for evaluation. On the first flight the pen vibrations were sometimes half the width of the chart paper, and obviously bore no relationship to water temperature. After successful lab tests a second flight produced the same results, and field tests were run to determine the cause. The IRT, recorder, and power supply were set up on a concrete apron twenty feet from the aircraft and out of the propeller slipstream. The sensing head was aimed at the pavement. When the aircraft engine was started the pen began to swing wildly. Range of these vibrations could be controlled by varying engine power. With the engine off electrical circuits had no effect, but radio transmissions caused the pen to go off scale. Interference from a truck engine was also noted. A turbojet 400 yards distant caused large scale needle fluctuations while taxiing toward or broadside to the instrument, but hardly affected the pen when moving directly away. Improper or incomplete shielding of critical components was reported to have been the source of trouble.

Tests on the York River Bridge pointed up several problems, some of which have not been explained. During testing the sensing head was secured to an outside railing on the Bridge Tender's house about 100 feet above the river. Angle of view was nearly vertical. Check instruments were mounted on a platform 10 feet above the water in the supporting caisson. During the week the following "types" of days were experienced:

1. Sunny, sky clear, relative humidity moderate, wind 5-12 mph
2. Scattered clouds, relative humidity moderate, wind 25-40 mph
3. Overcast, relative humidity high, wind 20-30 mph
4. Overcast sky, dense fog in morning, drizzle in afternoon, relative humidity high, wind 3-15 mph

During the calm sunny day, readings between IRT and check instruments were extremely close. High wind on the second day, however, affected the readings and made the needle "nervous". A large cardboard box fitted over the sensing head eliminated much of the trouble and when the sensing head was moved to the lee side of the building, the needle was stable. It is suspected that even gusts of relatively low velocity affect readings noticeably if the sensing head is exposed. Accuracy was high during the overcast period but fog and drizzle on the fourth day caused errors of large magnitude. IRT readings were generally high, an expected result as the air temperature (and thus the temperature of the fog) was higher than the river water. As the area was relatively protected, no high sea states were observed, but large pressure waves passing through the field of view had no apparent effect. A flat calm sea surface caused anomalous high readings attributed to solar warming of the poorly mixed upper layer.

Further tests were made by tilting the sensing head at different angles ( $90^\circ$ ,  $80^\circ$ ,  $70^\circ$ ,  $60^\circ$ ,  $50^\circ$ ). Normally no changes were noted until 60 or even 50 was reached, but twice at 70 the needle jumped more than  $10^\circ\text{F}$ . No clue as to cause could be ascertained from the physical conditions. As no fog was visible, it is concluded that sea state may be a factor. The same unexplained variations have been noted during aircraft banking.

## BIBLIOGRAPHY

- Anderson, H. G., MS 1963, Some small considerations of the effect of cloud on an airborne radiation thermometer: Fish. Res. Bd. Canada Circ. 1963-2
- Barnes, R. C., 1963, Monthly sea-surface temperature charts of Atlantic shelf waters: Va. Inst. Mar. Sci. survey reports
- \_\_\_\_\_, 1964, Sea-surface temperature studies using airborne infrared radiation thermometer (IRT) (Abstract): Va. Jour. Sci. 15 (4)
- Clark, John R., 1962-4, Monthly sea-surface temperature charts of Atlantic shelf waters: Sandy Hook Marine Laboratory survey reports
- \_\_\_\_\_, and Frank, John L., 1963, Infrared measurement of sea-surface temperatures: Undersea Technology, vol. 4, 10 Oct 63, p. 20-23
- DeWaard, R., and Wormser, E. M., 1959, Description and properties of various thermal detectors: Proc. IRE 47, p. 1508
- Drennan, Kirby L., 1963-4, Monthly sea-surface temperature charts of Gulf of Mexico waters: Gulf Research Laboratory survey reports
- Ewing, G., and McAlister, E. D., 1960. On the thermal boundary layer of the ocean: Science 131, p. 1374-76
- Jacobs, S. F., 1960, Characteristics of infrared detectors: Electronics 33, p. 72-73
- Johnson, E., Airborne radiation thermometer (Part II): vol. 6, no. 2, Proc. IRIS
- Jones, R. C., 1959, Phenomenological description of the response and detecting ability of radiation detectors: Proc. IRE 47, p. 1495
- Lorenz, Dieter. 1962, Messungen der Bodenoberflächentemperatur vom Hubschrauber aus: Berichte des Deutschen Wetterdienstes, nr 82 (Band 11)
- NODC Newsletter. 30 April 63, p. 1: Bureau of Sport Fisheries and Wildlife inaugurates monthly temperature survey of mid-Atlantic shelf (Sandy Hook Marine Laboratory)
- NODC Newsletter. 30 Sept. 63, p. 6: Continental shelf temperature surveys initiated on Pacific Coast (U.S. Bureau of Sport Fisheries and Wildlife, Tiburon Marine Laboratory)
- NODC Newsletter. 30 Nov. 63, p. 2: Virginia Institute inaugurates aerial measurements of sea-surface temperatures along mid-Atlantic shelf (Virginia Institute of Marine Science)

- NODC Newsletter, 30 Nov. 63, p. 3: Gulf Coast Research Laboratory begins aerial temperature survey of northern Gulf of Mexico (Gulf Coast Research Laboratory)
- Peloquin, Robert A., 1963, Airborne oceanographic instrumentation: Paper presented at Great Lakes Navy Research and Development Clinic, Ohio State University (Unpublished Manuscript), 8 p., 17 figs.
- Pirart, Marcel, MS 1961, Airborne radiation thermometer (FRB-1): Fish. Res. Bd. Canada, MS report (Oceanography and Limnology), no. 102, 20 p.
- Richardson, W. S., and Wilkins, C. H., 1957, An airborne radiation thermometer: Deep-Sea Research, 5, p. 62-71
- Sowden, W. J., 1962, Report on the flying of an airborne radiation thermometer: Meteorological Branch, Dept. of Transport, Toronto, Canada, circ. 3778 TEC-445
- Stommel, H. *et al*, 1953, Rapid aerial survey of the Gulf Stream with camera and radiation thermometer: Science, 117, p. 639-40
- Tully, J. P., Pirart, M., and Lane, R. K., MS 1960, Airborne radiation thermometer Mark I feasibility tests: Fish. Res. Bd. Canada, MS report (Oceanography and Limnology), no. 61, 13 p.
- \_\_\_\_\_, MS 1961, Assessment of temperature structure in the eastern subarctic Pacific Ocean: Fish. Res. Bd. Canada, MS report (Oceanography and Limnology), no. 103, 38 p.
- \_\_\_\_\_, and Giovando, L. F., 1963, The seasonal thermocline in the eastern subarctic Pacific Ocean: Mar. Dist., The Royal Soc. of Canada, spec. publ. 5, Univ. Toronto Press
- VonArx, W. S., and Richardson, W. S., 1953, The surface outcrop of the Gulf Stream front: Woods Hole Oceanographic Institution, Tech. Rept. Ref. 53-24 (Unpublished Manuscript)
- \_\_\_\_\_, Bumpus, D. F., and Richardson, W. S., 1955, On the fine structure of the Gulf Stream front: Deep-Sea Research, 3, p. 46-65
- Weiss, M., Airborne radiation thermometry: vol. 6, no. 2, Proc. IRIS
- \_\_\_\_\_, and Peloquin, Robert A., 1963, Airborne radiation thermometer (Two parts): Informal Manuscript Report 0-16-63, U. S. Navy Hydrographic Office (Unpublished Manuscript), 19 p. 11 figs.

Wilkerson, J., Peloquin, R., and Perloth, J., 1963, Airborne radiation thermometer survey  
Tongue of the Ocean, 5 through 9 February 1963: Informal Manuscript

Wormser, Eric M., 1962, Measurement of oceano-surface temperatures in Fundamentals  
of Infrared Technology: New York, The Macmillan Company, 442 p.

Yates, H. W., and Taylor, J. H., 1960, Infrared transmission of the atmosphere: N.R.L.  
Report 5433



# THE INFRARED SURVEY TECHNIQUE AS A MEANS OF DETERMINING MISSISSIPPI RIVER DISCHARGE PATTERNS AND SURFACE FLOW ALONG THE NORTHERN GULF COAST

by K. L. Drennan, Gulf Coast Research Laboratory,  
Ocean Springs, Mississippi

## INTRODUCTION

The Gulf Coast Research Laboratory under sponsorship of the Geophysics Branch of the Office of Naval Research is conducting a study of the circulation along the northern coast of the Gulf of Mexico. The program, conducted on a rather limited scale during the past three years, was confined to a study of the distribution of temperature and salinity in the upper layers of the area immediately east of the Mississippi Delta. Drift bottles were released in conjunction with the study to obtain approximations of surface current speed and direction.

These data along with some direct current measurements have enabled us to determine, to some extent, the seasonal variations in Mississippi River discharge patterns and surface currents in the area.

Previous investigations have shown that water masses of the area could in some instances be delineated on the basis of temperature alone. This is particularly true during fall, winter, and spring when the inshore and Mississippi River waters were in some instances 30 - 35° F colder than the open Gulf waters.

A monthly aerial temperature survey was initiated along the northern Gulf Coast which would provide near synoptic surface temperature data from the area, and from these data, the space-time variations in surface flow could possibly be determined. The initial flight was made in November 1963.

## INSTRUMENTS

Sea surface temperature measurements are made using the Barnes model IT-2S infrared radiation thermometer (IRT). The thermometer and complementary equipment are mounted in a Grumman Albatross, the Coast Guard and Navy's standard search and rescue aircraft, and measurements are made from an altitude of 300 feet and speed of approximately 140 knots. The sensing head is directed from near vertical position toward sea surface through lower half of rear emergency exit. Complementary equipment includes an Accurate Instrument Company model APS-9AB-1 28VDC to 115 volt 60 cycle inverter. The inverter has a frequency tolerance of  $\pm 0.05\%$  with input variations of 24 - 32 VDC. A Nesco model 212 dual pen strip chart recorder is used to record temperature and variations in line voltage.

## CALIBRATION OF INFRARED THERMOMETER

Two calibration tests were run at three month intervals in the Laboratory, using a fast circulating temperature controlled bath to determine accuracy of the thermometer over the normal operating range of 40 - 92°F.

The results obtained are shown in Figure 1. Accuracy of thermometer under these conditions was found to be within  $\pm 1.0^\circ\text{F}$ , and appears to be fairly stable.

### FIELD TESTS

Sea surface temperature measurements and meteorological data were obtained over a 48 hour period from stationary platform in 60 feet of water located at  $30^\circ 07.2' \text{ N}$  &  $85^\circ 46.5' \text{ W}$ , or 1.75 N miles offshore southwest of Panama City, Florida.

Radiation measurements were made from a height of 45 feet above mean sea level at intervals of one hour during the 48 hour period.

Measurements of surface temperature using bucket thermometer, air temperature, wet bulb temperature, relative humidity, rainfall, barometric pressure, wind direction and speed, and vertical temperature structure, using bathythermograph, were made in conjunction with the IRT measurements to obtain more information relative to energy exchange across air-sea interface, effect of varying atmospheric conditions and accuracy of instrument under simulated operating conditions.

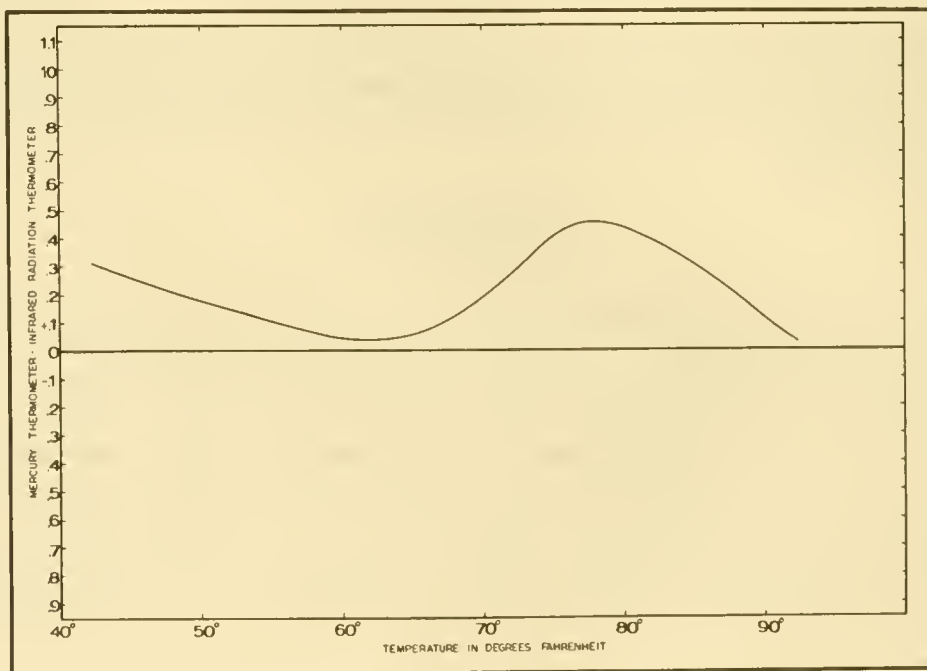

Figure 1. Results of calibration test using temperature controlled bath to determine accuracy of infrared thermometer

Results of previous investigations by other workers have shown wide variations between radiation measurements of micro-surface temperatures and conventional bucket temperature measurements when air and sea temperature differences are large, moisture content of atmosphere is high, or when relatively little mixing is occurring along air sea interface.

Weather conditions and temperature variations during the period of observation were as follows: Air temperatures varied only 6.0°F. (54.0° to 60.0°F), during the 48 hour period and sea surface temperatures, from bucket thermometer, varied 0.9°F (54.6° to 55.5°F). Relative humidity, 50 - 90%; wind speed, 7 - 34 knots; average speed approximately 20 knots; prevailing wind direction from west; skies overcast; rainfall approximately 0.7 inches.

Waves and swells ranged in height from 2 - 9 feet during period of observation.

Surface temperatures from radiation and bucket thermometers were, in most instances, within 0.5°F, the accuracy to which radiation thermometer can be read due to the 2°F scale division of readout meter.

Temperature differences of 4.0° - 4.5°F between IRT and bucket thermometer measurements were experienced by lowering 60 cycle power supply to 58.4 cycles per second.

Plots of radiation minus bucket temperature measurements versus time and air minus bucket temperature versus time show no correlation.

Measurements of sea surface temperatures using infrared radiation thermometer under conditions described, were well within the absolute accuracy limits of  $\pm 2.0^\circ\text{F}$  specified by manufacturer. The accuracy obtained under conditions described was possibly due to rapid mixing of surface layer and the small air-sea temperature difference.

### PRESENT PROGRAM

The area covered on the flight path, and drift bottle and sea bed drifter release points are shown in Figure 2. Aircraft assistance for areas east and west of Southwest Pass is provided by the Pensacola Naval Air Station, Pensacola, Florida, and the U. S. Coast Guard Air Detachment, Biloxi, Mississippi, respectively. Total flying time required is approximately 16 hours.

Flights are scheduled for coverage of the entire area during a 48 hour period whenever possible. However, we have been unable to accomplish this thus far, due to weather, available aircraft, etc.

Simultaneous measurements of surface temperature and meteorological conditions are obtained at two points over northeastern sector.

Surface and sub-surface temperature data along with other pertinent meteorological data are furnished by the U. S. Fish and Wildlife Service in Galveston, Texas from their

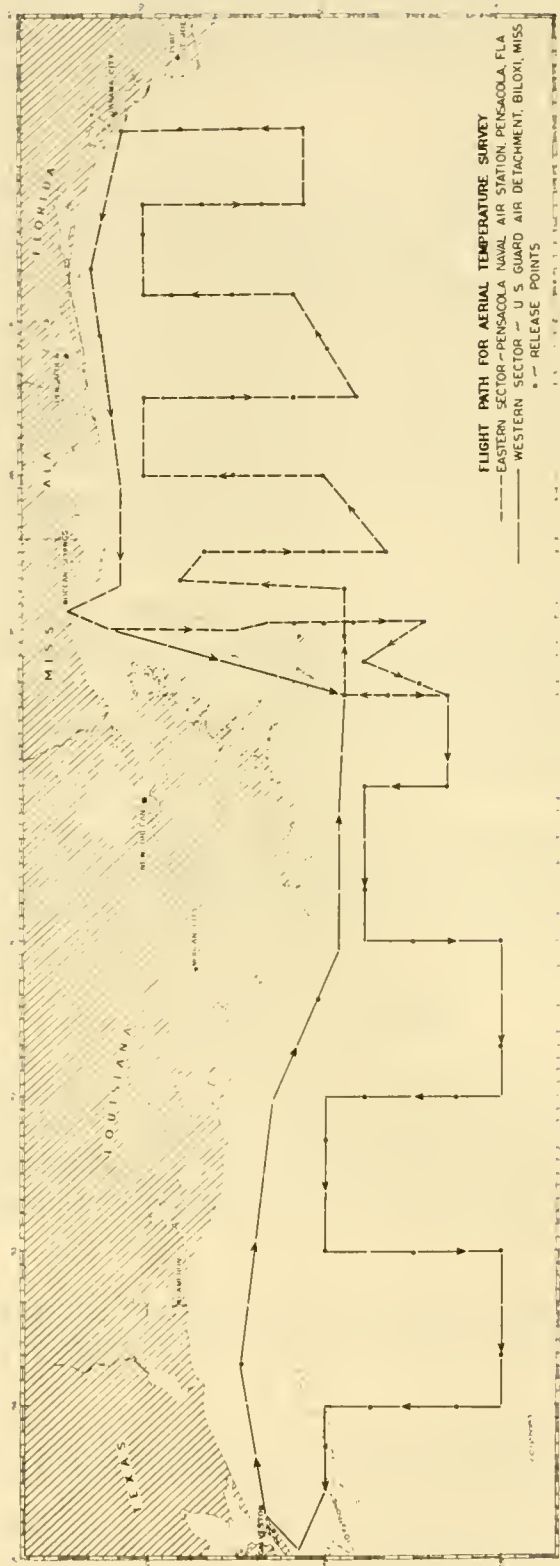

Figure 2. The area covered on flight path, and drift bottle and sea bed drifter release points



monthly cruises along approximately the same track flown on aerial temperature survey of northwestern sector.

The temperature and drift bottle recovery data from in-flight releases have provided a more comprehensive description of surface flow in the northeastern sector. An example of the data obtained is shown in Figures 3 and 4.

The most prominent features indicated from the isotherm patterns are as follows: (1) an intrusion of warmer offshore water into the region southeast of the Mississippi Delta indicating a flow roughly paralleling depth contours; (2) strong temperature gradients in the area south and east of the Delta indicating variations in river discharge patterns and a significant increase in volume outflow during February and March; (3) anomalous temperatures in the canyon area south of Pensacola, Florida.

These temperature anomalies suggest an area of upwelling or the existence of an eddy.

The data obtained from these surveys and other efforts provide no basis for an evaluation of the absolute accuracy of the IRT when used for aerial surveys. It is suggested, however, in the area described that a greater error is introduced due to inaccuracy of navigational systems than those of the instrument itself when strong temperature gradients exists.



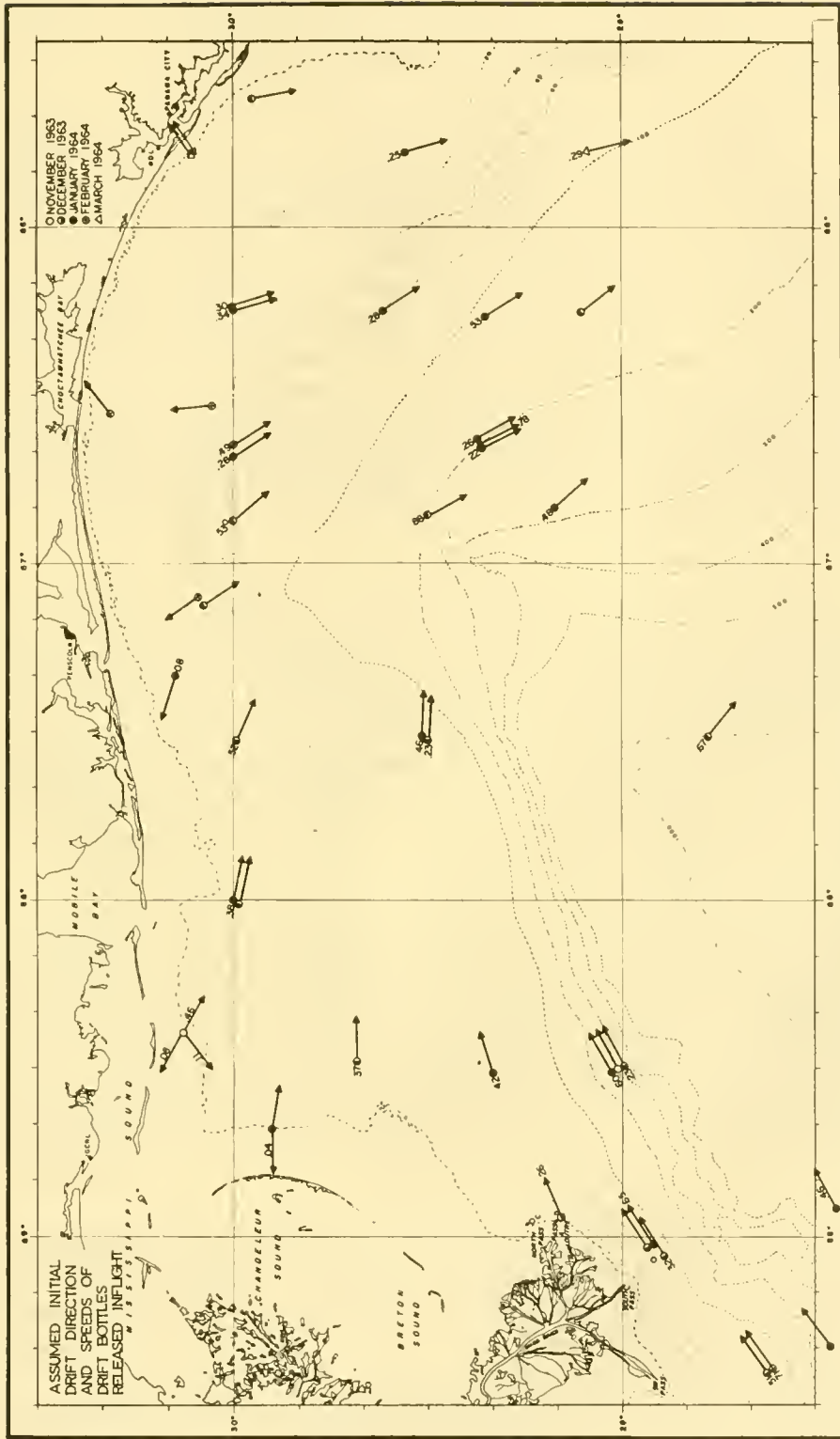

Figure 4. Assumed initial drift direction and speed of drift bottles released in flight

# OBSERVATIONS OF SOME PHYSICAL FACTORS AFFECTING THE USE OF AN AIRBORNE RADIOMETER

by James L. Squire, Jr., Tiburon Marine Laboratory,  
Tiburon, California

The physical parameter of sea surface temperature in relation to the distribution and abundance of important eastern Pacific marine fishes has been of interest to the biological oceanographer for at least four decades. A rapid synoptic survey of this environmental parameter is needed to test its correlation with the occurrence of pelagic migratory fishes. An observation on the possibility of obtaining rapid, nearly synoptic ocean surface temperature surveys using airborne infrared equipment was made by Ewing (1952) as the result of conducting experimental surveys in the tropical eastern Pacific. In the fall of 1962 the Tiburon Marine Laboratory began experiments and field surveys using an airborne infrared radiometer. To date, the instrument has been used in five types of aircraft (Cessna 172, Champion, Grumman UF (Albatross), Martin P5M and P2V) for a total of approximately 310 hours of airborne operations.

A Barnes Engineering Company model 14-312 radiometer mounted in a Cessna 172C was used in initial field tests and surveys. A series of water surface observations was made at several elevations and compared with simultaneous observations taken at water level (see section on meteorological effects). Repeatability tests were run from upper Tomales Bay, California, to over the Pacific, an area where differences in water temperatures were available over a short geographical distance. Repeatability within a short period of time (5-15 minutes) of surface water measurements taken at selected points along the flight track to  $< -0.5^{\circ}$  was indicated. These observations were published by the Barnes Engineering Company (Anon. 1962).

Surveys were made of nearshore temperatures (1/2 to 1 mile offshore) from Cape Flattery, Washington, to Mexico and of the waters from north San Francisco Bay to a point north of Sacramento, California, on the Sacramento River, and of the marine outfalls of steam-electric generating plants. In April 1963, surveys were conducted at 24 hour intervals for four days, of the Santa Barbara channel as part of Operation C.O.W. (Cooperative Observational Week (Frank, 1960)). Observations of temperature gradients in relation to wind flow patterns in situations of wind velocities of less than 1 knot to greater than 25 knots were observed over a short geographical distance.

In August 1963, monthly IRT (infrared thermometer) survey flights of three West Coast continental shelf areas were initiated in cooperation with the U. S. Coast Guard. The IRT flights are continuing and sea surface isotherm charts are published by the Tiburon Marine Laboratory for each area.

IRT airborne instruments and accessories presently used for monthly surveys are listed as follows:



- Radiometers
  - a. Barnes Engineering model 14-312
  - b. Barnes Engineering model IT-2
- Recorders
  - a. Rustrak 0-1 ma D.C., 30"/hr.
  - b. Varian G-14, 1" or 4"/min.
- Power supplies - ATR inverter (American Television and Radio)
  - a. 12 Vdc. to 120 Vdc., 60 cy.
  - b. 28 Vdc. to 120 Vac., 60 cy.

Plus voltmeters, clocks, mounting panel for IRT console and recorder, and shock-mount for detector.

Observation on the field operation of the airborne IRT reviewed in this paper will attempt to answer some of the questions regarding physical effects upon the instrument readout, its accuracy in measurement of sea surface temperature, described by Weiss (1962) to be within 0.5° F., and conclusions regarding its field use.

### CALIBRATION

The measurement of "sea surface temperature" as generally defined and practiced in most routine observations is a highly variable measurement, even with a mercury thermometer. It is dependent upon the accuracy of the instrument, the depth of the water sample, and the position of the water sample in relation to objects (hull, piling, etc.) from which the sample is taken, and their relation to wind and current.

One of the problems in conducting IRT surveys is the calibration of the instrument to give an accurate and therefore reliable picture of sea surface temperatures. The IRT is an electronic instrument of complex circuitry and is subject to changes in the resistance and capacitance of its electronic components throughout its useful life. These changes can result in the gradual decrease in the original calibration accuracy. Therefore, IRT meter readouts from our instruments usually vary from known temperatures. The reasons for the variations are not completely understood. However, the operation of the IRT from an aircraft moving at a high rate of speed 500' above the surface is placing the instrument in an environment of high vibration and electronic noise that is not the same condition as experienced in the laboratory.

An IRT calibration check requires a controllable radiation source having the approximate emissivity of unity. Clark and Frank (1963) state the ocean surface has essentially the characteristics of a blackbody radiation source in the infrared region from 4 to 13 microns, its emissivity (0.98) is nearly unity. To meet the needs of field operations, and since we do not have a controlled blackbody reference source, a controlled temperature water bath equipped with a magnetic stirrer has been used. The IRT detector is positioned at a three foot distance from the water. This allows the calibration of a recorder readout grid directly from water temperature as determined by an accurate mercury thermometer.

Since a large number of electronic and physical variables are influencing the measurement of sea surface temperatures with both the airborne IRT observation and mercury surface cast, the problem of calibration for IRT surveys over large sections of ocean within a relatively short period of time is accomplished using the following technique. After each survey flight a readout grid is obtained in the laboratory by observing water temperatures within the range of those obtained during field operations. During the flight, a surface temperature observation is obtained from a reliable source, such as the Naval Electronics Laboratory (N.E.L.) oceanographic tower of U.S.C.G. lightships using U. S. Weather Bureau surface thermometers. The recorder chart is marked at the moment of passing over a point where the comparative observation is being taken.

In the laboratory the IRT recorder readout grid is adjusted to the mercury sea surface thermometer observation, and readouts are made on an average of every 30 seconds of flight. These are averaged for each two minutes of flight, plotted on the master chart and isotherms drawn for each one °F. change. The accuracy of charts issued by the Tiburon Marine Laboratory is estimated to be within 1.0°F. of the mercury thermometer sea surface temperature observation as determined by the most reliable source available.

#### COMPARISON OF AIRBORNE IRT AND SEA SURFACE OBSERVATIONS

The laboratory limits of sensitivity ( $> 0.5^{\circ}\text{F.}$ ) and accuracy ( $\pm 2^{\circ}\text{F.}$ ) for infrared detectors of the type used in these observations have been established by the manufacturer. Interest in the field use of an airborne unit for determining sea surface temperatures raises the question of the limits of accuracy for temperature ranges normally observed during field surveys. Comparisons of IRT meter readout temperatures taken in September 1963 from a U. S. Coast Guard aircraft over the N.E.L. oceanographic tower and the San Francisco lightvessel were within about  $-0.4^{\circ}\text{F.}$  for the N.E.L. tower and about  $-0.2^{\circ}\text{F.}$  for the San Francisco lightship. Four checks were made over the lightvessel within a 20 minute period and each check resulted in the recorder returning to the same point.

In the normal marine environment it is difficult to find an area having wide range of temperatures over which the instrument can be tested. However, about the outfalls of steam-electric generating plants using sea water as a cooling medium for steam condensers, a situation exists where changes in sea surface of up to  $20^{\circ}\text{F.}$  might be observed.

The following comparative data for an airborne IRT (model IT-2) calibrated in the laboratory and for surface temperatures taken from a small boat using a standard thermometer has been made available through the cooperation of Mr. Joseph Joy and Mr. James Jones of Marine Advisers, Inc., La Jolla, California, and the engineering department of Southern California Edison Company.

Location : Offshore from Southern California Edison Huntington Beach generator plant; observations taken close (within 1/4 mile) to the cooling water outlet.

Date : August 28, 1963.

Time : a. IRT airborne observations are taken from flight track flown from 1220 to 1240 P.D.T. and read directly from a Varian G-11 recorder.

b. Sea surface observations used for comparison were those having a close proximity to the aircraft track and were taken by small boat from 1253 to 1357 P.D.T.

Weather and Sea : Wind W-SW about 10 k. Fresh to 12-15 k. by 1500. Choppy low swell from the S.

<u>TIME</u>	<u>Sea Surface Obs. °F.</u>		<u>Comparison</u>
	<u>IRT</u>	<u>MERCURY</u>	<u>IRT to MERCURY</u>
1253	68.0°	68.4°	-0.4°
1305	69.0	68.2	+0.8
1313	68.0	68.4	-0.4
1319	69.0	68.1	+0.9
1327	72.5	72.4	+0.1
1328	68.0	68.3	-0.3
1331	69.4	69.0	+0.4
1332	72.0	71.7	+0.3
1336	68.0	68.9	-0.9
1338	70.0	70.3	-0.3
1342	69.0	68.6	+0.4
1346	74.0	74.4	-0.4
1349	74.5	74.8	-0.3
1355	68.4	68.0	+0.4
1357	68.0	68.4	-0.4

Range -- IRT 68.0° to 74.5° F. = 6.5° F.

MERCURY 68.0° to 74.8° F. = 6.6° F.

Difference - IRT 0.1° < Mercury surface reading

## EFFECTS OF METEOROLOGICAL CONDITIONS

### Haze Effect

On November 21, 1962, observations were made of surface water temperatures off a pier in north San Francisco Bay with a Barnes 14-312 mounted in a Cessna 172C and compared with simultaneous mercury temperatures taken from the pier. Five observations were made at 500' M.S.L., six at 1000', three at 1500', two at 2000' and two at 3000'. The weather was clear, wind calm, visibility 6 miles, haze level extending to an estimated 2100' M.S.L. Variations at each elevation, compared to a simultaneous reading of water surface temperature were:  $-0.2^{\circ}$  to  $-0.5^{\circ}$  F. @ 500',  $-0.2$  to  $-0.5^{\circ}$  F. @ 1000',  $-0.5^{\circ}$  @ 1500',  $-0.7^{\circ}$  to  $-0.8^{\circ}$  F. @ 2000' and  $-0.7^{\circ}$  to  $-1.0^{\circ}$  F. @ 3000'. Observations were averaged for each elevation, giving a reduction in temperature from bay water temperature of  $-0.32^{\circ}$  F. @ 500',  $-0.36^{\circ}$  F. @ 1000',  $-0.50^{\circ}$  F. @ 1500',  $-0.72^{\circ}$  F. @ 2000' and  $-0.85^{\circ}$  F. @ 3000' (see figure 1). The greatest change in readout temperature was within the first 500' ( $-0.32^{\circ}$  F.), indicating that haze plus the possibility of evaporative cooling as described by Ewing and McAlister (1960) might be affecting the readout. A stratification of haze was not apparent to the eye within the layer although the haze appeared to be denser in the lower 1000 feet. On figure 1 a straight line, fitted by eye, from the 500' to the 2000' observation level in weather condition as indicated above indicates an approximate reduction of  $-0.68^{\circ}$  F. per 1000 feet.

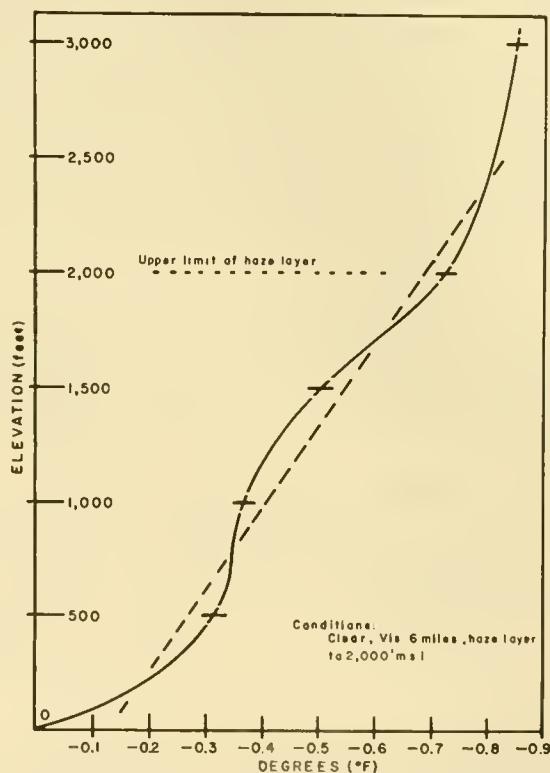

Figure 1. Haze effect observations; November 21, 1962;  
1348-1447 P.S.T.; North San Francisco Bay



## Low Thin Stratus

Upon passing over low scattered thin stratus (tops less than 100') prior to going over solid overcast, no effect on temperature was noted until the aircraft passed over the solid overcast. At this point the IRT readout usually dropped at least 2-4° F. The possibility exists that the temperature of the low thin stratus is very close to sea surface temperature, and this may account for no observable temperature change.

## Rain Showers

Variable effects on sea surface temperatures have been found when entering rainstorms. A noticeable drop in temperature has sometimes been experienced when entering winter rainstorms. This drop appears to be more common in the northern latitudes, as it has been encountered in flights off the central and northern portion of the West Coast. This reduction in temperature could be the effect of low temperature rain or hail in the field of view or a cooling of the water surface upon which it fell. Light summer rain showers do not usually appear to affect sea surface temperature readout, probably because the rain is near water surface temperature.

## Air Temperature

Experience with the airborne radiometer off the West Coast has been confined to the temperate zone from latitude 32° N. to 48° N., an area not noted for large differences between air and sea temperatures within the lower portion of the marine layer. Air temperatures were obtained at the 500' M.S.L. level on three survey flights (see figures 2-4). Temperatures were obtained by positioning a thermistor probe in the aircraft slipstream. The probe readout temperatures were corrected for dynamic heating as a function of air speed and rounded off to the nearest °F., using the formula:  $T = \frac{(A.S.)^2}{100}$  A.S. (air speed) in mph., T in °C. At an estimated air speed of 130 knots  $T = 2.25^\circ$  C. or approximately 4° F. higher than true ambient air temperature.

Weather conditions during the flights (figures 2-4) were:

Figure 2. -- Southern half, overcast 1000' to 1500' broken to scattered, wind 0-8 k. W-SW, visibility 10 miles. Northern half, broken to scattered, wind 0-10 k. W-NW, visibility reduced to 3 miles in Santa Barbara channel area.

Figure 3. -- Overcast, solid to scattered, wind 10-15 k. NW Offshore from Pt. Conception area, 0-6 k. elsewhere.

Figure 4. -- Overcast, solid, wind 0-5 k. SW.

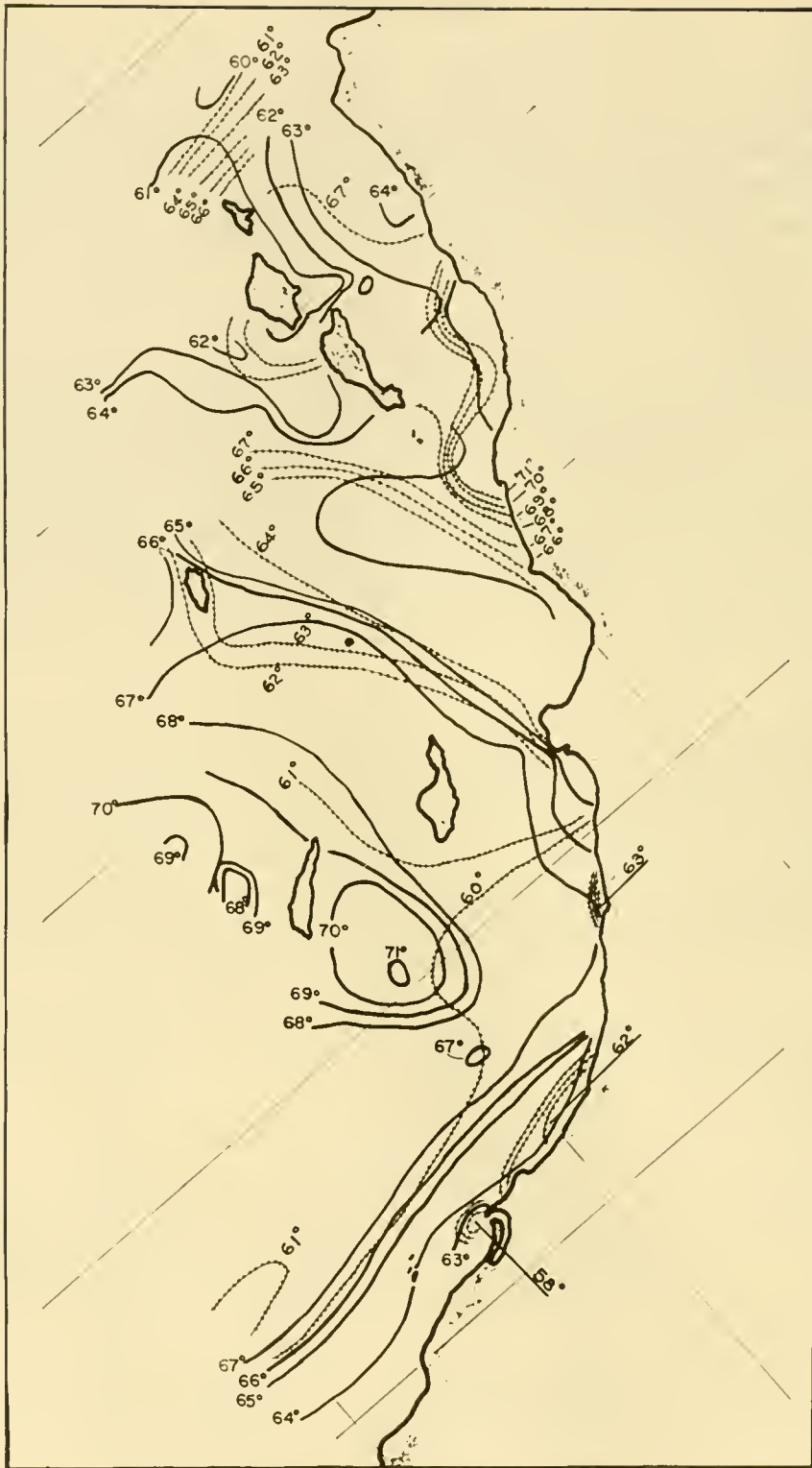

Figure 2. Surface water temperature survey with IRT; date: 10/31/63;  
 time: 1950-1648 P.S.T. Air temperature °F, dotted line.  
 Water temperature °F, solid line.

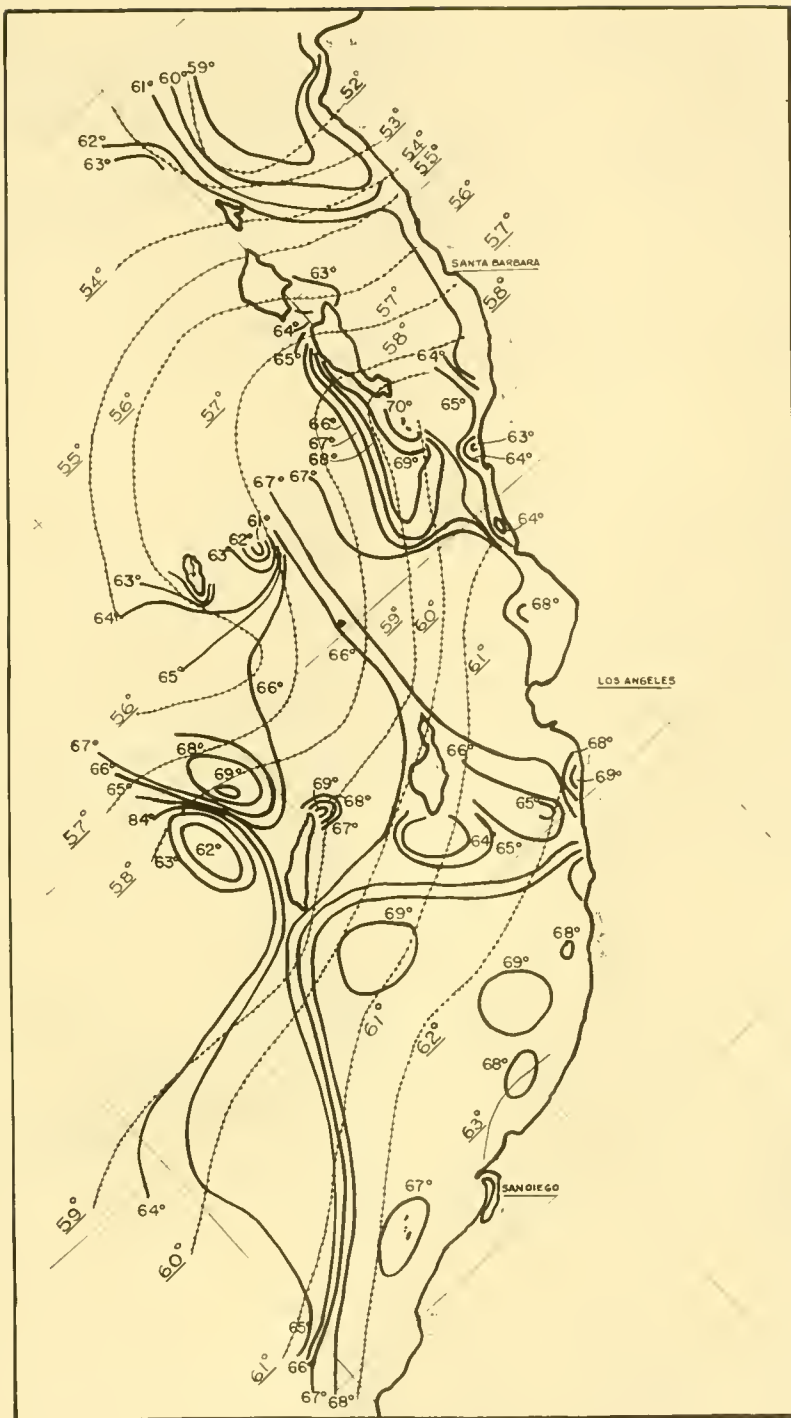

Figure 3. Surface water temperature survey with IRT; date:  
 8/1/63; time: 1952 -1648 P.D.S.T.  
 Air temperature °F, dotted line.  
 Water temperature °F, solid line .

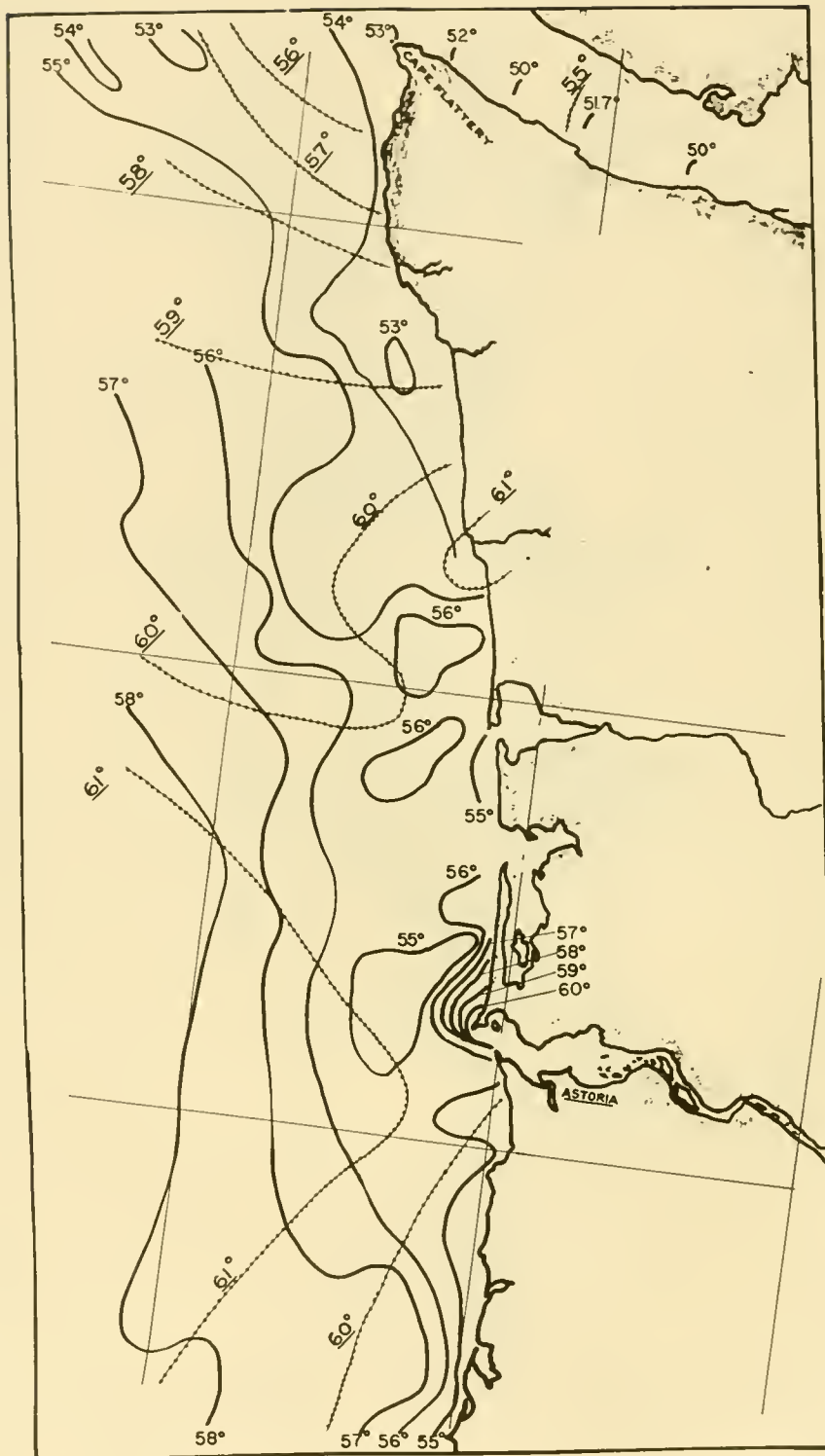

Figure 4. Surface water temperature survey with IRT; date: 8/13/63; time: 1213-1830 P.D.S.T. Air temperature °F, dotted line. Water temperature °F, solid line.



Air temperature isotherms at 500' M.S.L. usually do not show a general relationship in direction with sea surface isotherms. Figure 2 shows closest isotherm relationship in the central portion. Wind velocities were low (0-4 k.) in this area, and stable conditions may have resulted in a paralleling of sea surface and air temperature isotherms. Figure 3 shows less of an overall paralleling of isotherms, however, the southern portion shows a remote relationship. In figure 4, the northern survey area, the gradients appear to have only a slight relationship in the northern and southern portions. At an elevation of 500' it is likely that the aircraft may fly into an inversion layer and figure 4 shows this as the air temperature is above sea surface temperatures. From these observations it appears that air temperature isotherms as observed in the eastern Pacific temperate region at 500' M.S.L. appear to not be directly aligned with sea surface gradients obtained with the airborne IRT.

### Wind Flow

As part of a cooperative program to measure oceanographic and meteorological parameters operating in the Santa Barbara channel (Operation C.O.W.), four flights at daily intervals were conducted in late April and early May 1963 on a predetermined track over the channel. The flight track followed the coast line westward from Santa Barbara to Point Conception, a point often defined as a zoogeographical and climatological dividing point. Sea temperatures are known to decline rapidly with an increase in NW winds and sea state when approaching Point Conception from the Santa Barbara channel. Wind flow pattern in relation to sea surface isotherms, as determined by a Barnes 14-312 IRT, can be compared in figures 5-9. Wind speeds were observed on one flight to range from near zero knots along the Santa Barbara coast to over 30 knots off Pt. Conception. Isotherms appear to follow wind flow in the northwestern end of the Santa Barbara channel, an area of higher velocities than in the other parts of the area.

Sea surface isotherms sometimes appear to generally follow wind flow patterns around prominent geographical points of land, such as Pt. Conception, and islands off southern California, either through heating of the sea surface layers by radiation heating and air warmed from passage over a land mass combined with low velocities on the surface or from the results of upwelling along a lee shore. The paralleling of isotherms with wind flow appears not to be significant in offshore areas, and wind flow patterns experienced in these areas during coastal surveys have at times been near 90° to the sea surface isotherm gradients. Figures 2, 3, and 4 indicate surface flow directions that are not generally aligned with the isotherm pattern.

### Mounting Problems

Coastal IRT surveys use a U. S. Coast Guard Grumman UF-2, and since this aircraft is not equipped with camera hatches or other openings in the hull bottom, a faired housing with shock mounting for the detector head was fabricated for attachment to the starboard Jato rack. This installation allowed a vertical view of the sea surface. The vertical view of the sea surface is more desirable than an angular view, since on turns care must be taken to delete a portion of record as the detector head views part of the horizon and gives false reading.

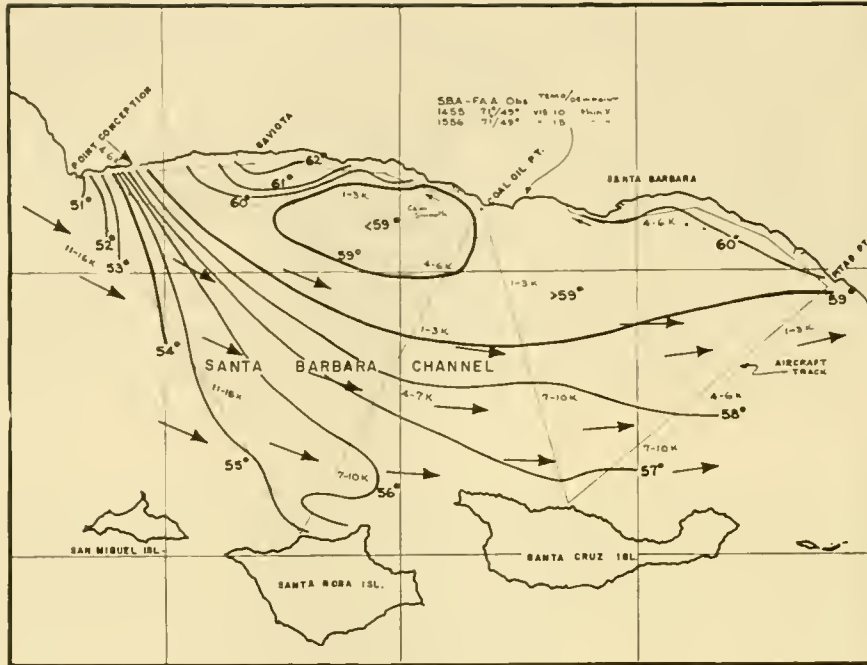

Figure 5. Wind direction and surface isotherm pattern, southern California, April 29, 1963

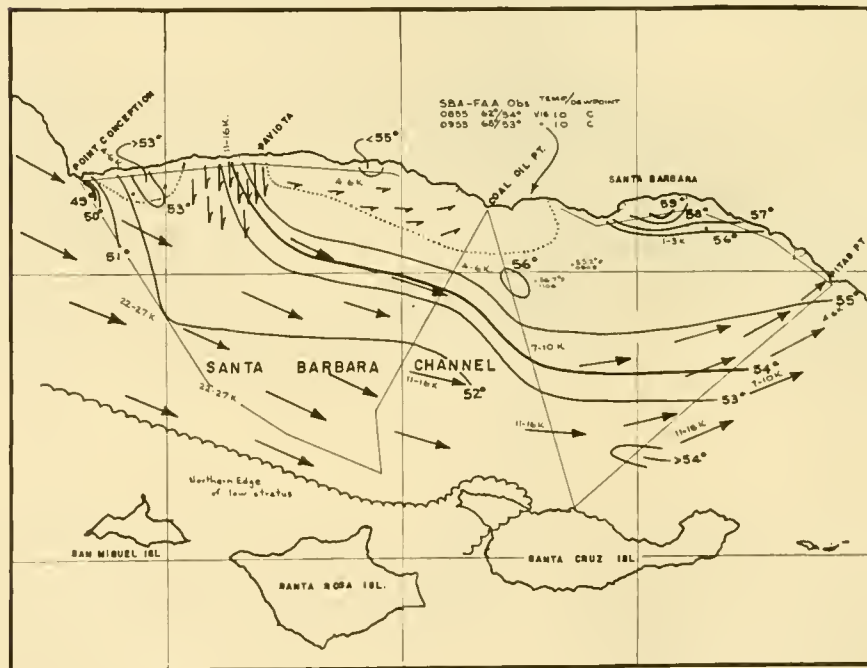

Figure 6. Wind direction and surface isotherm pattern, southern California, April 30, 1963, morning

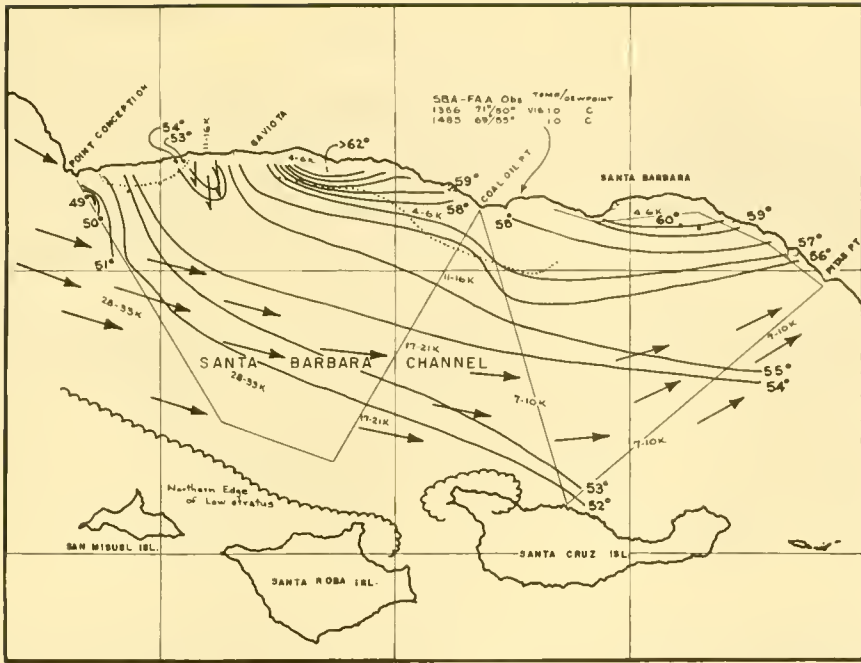

Figure 7. Wind direction and surface isotherm pattern, southern California, April 30, 1963. afternoon

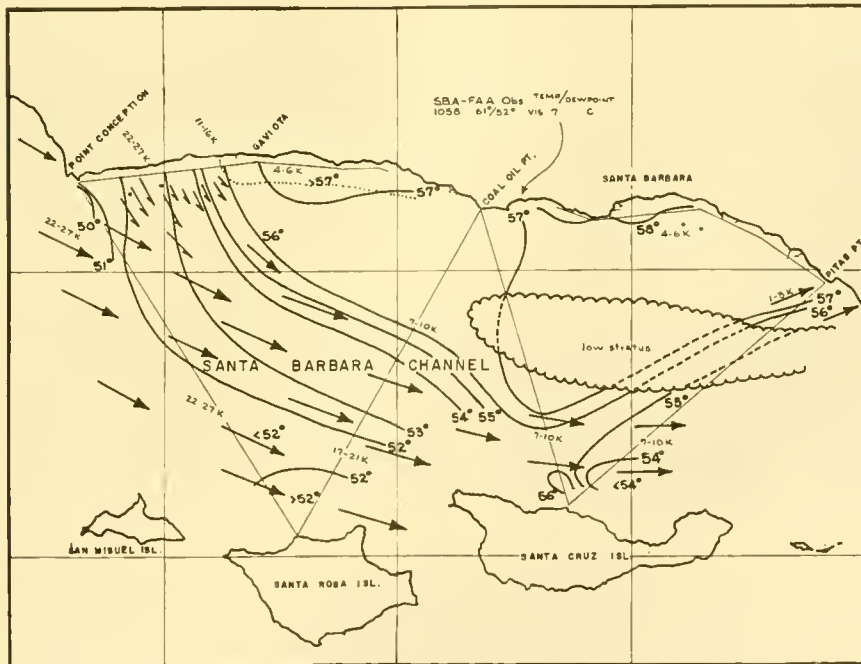

Figure 8. Wind direction and surface isotherm pattern, southern California, May 1, 1963

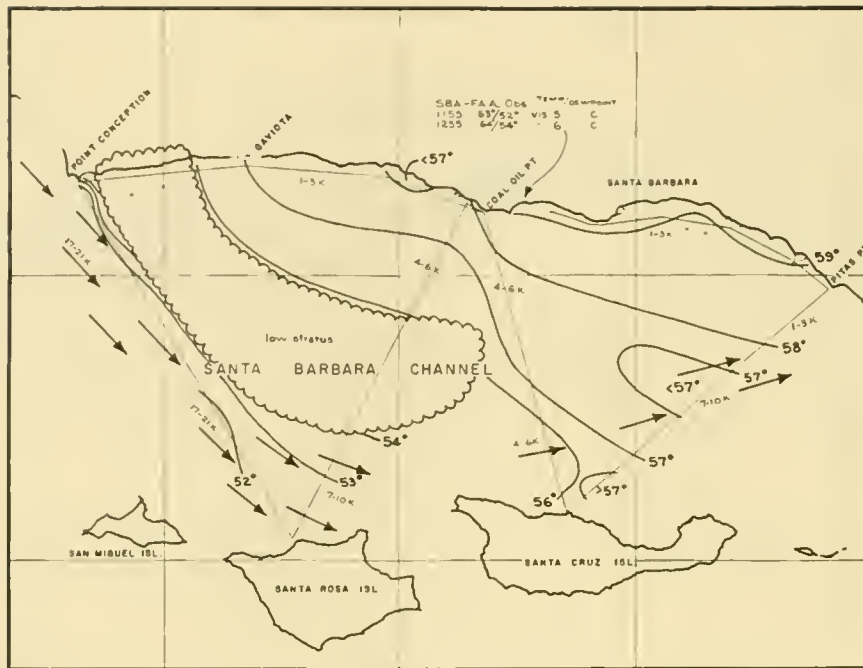

Figure 9. Wind direction and surface isotherm pattern, southern California, May 2, 1963

Initial IRT survey temperatures (Aug., Sept., Oct. 1963) for all three West Coast areas were higher than sea surface temperatures observed by conventional methods (Anon., 1963). Temperature error was greater in the northern surveys where air temperatures @ 500' were lower. In checking on this it was found that in the laboratory the normal heater cycle sequence in the IRT detector was 7 seconds on and 22 seconds off. This cycle time while airborne was extended to a sequence of up to 60 seconds on and 7 seconds off. The Barnes Engineering manual for model 14-312 infers that if the instrument was cycling at all, it could be considered to be operating properly.

To test the instrument while in flight, the detector head housing was removed from the Jato rack and the water surface observed by looking through the lower half of the port hatch. With the detector inside the aircraft, recycle time became normal (laboratory sequence), and the IRT readout dropped about 7° F. to 62.9° F., -0.4° F. lower than surface temperature observed by the N.E.L. oceanographic tower. Erratic fluctuations in chart record were greatly reduced and did not exceed 1° F.

The IT-2 instrument lacks a heater cycle on-off indicator due to the addition of a solid state proportional temperature controller. Therefore, an accurate check of heater operation is not possible. Tests indicate the chart record developed by the IT-2 increases in fluctuation after a period of time when the detector head is exposed to a light slipstream. Retraction of the detector head two or three inches has eliminated excessive chart fluctuations.



## INTERFERENCE

Large scale, sporadic, short term fluctuations in the chart record appear to have occurred during all of our survey flights. They appear to be more frequent in the vicinity of military installations or operations such as Pt. Mugu, Pt. Conception, Arguello and San Clemente Island. These points are key installations in the Pacific Missile Range and have considerable radar tracking and radio operations.

It has been confirmed that aircraft transmissions in the UHF band affect the chart readout, and fluctuations in the recorder have been noticed when in the proximity of naval warships. Whether these fluctuations are the result of high-frequency radar or UHF transmission is not known. Operation of the radar mounted in the Grumman UF appears not to result in interference, and on one survey flight aboard a P5M the 14-312 console and Varian G-14 were positioned within three feet of the bow radar reflector without interference.

## VIBRATION

The effects of vibration on the temperature readout has been noted during engine run-up and takeoff. However, the recorder stabilizes after takeoff and at cruising altitude.

Changes in propeller pitch and a resulting change in engine speed have caused chart fluctuations when using the IT-2. The source of error (detector or electronic console) is not known, but damping vibration of the console has stabilized the readout, and fluctuations did not occur again even though the propeller pitch and speed remained the same.

We have found that after attachment of the detector head directly to the air frame, vibration of the detector head was responsible for high amplitude fluctuations in the chart record. This was corrected by shock mounting the detector head.

## POWER SUPPLY

The 28 Vdc power source aboard heavy aircraft and the 12 Vdc source in light aircraft have been used to power the ATR inverters. Changes in the power system of the Grumman UF appeared not to affect the IRT readout temperature. A test was conducted by having the IRT view inside the aircraft water of known temperature and operating tests on: 1. 28 Vdc aircraft battery bank, engines stopped. 2. Engines started and at idle, 3. Engines accelerated to drive generator cut-out into charging position. No observable change in readout temperature was noted. Accessory electronic equipment aboard the aircraft as a source of noise has not been checked.

## CONCLUSIONS

Comparisons of carefully controlled and correctly calibrated airborne IRT observations at 500' with surface casts indicate a difference in temperature that falls to near the sensitivity limits of the instrument. Unless in-flight calibrations are made to reduce the many variables present in the determination of sea surface temperatures, both by the surface

cast and the airborne IRT, it is recommended that known reliable surface observations be obtained when over key points and the chart temperature grid adjusted to a known observation for readout.

Experience indicates that to obtain the best operating results with the model 14-312 or IT-2 IRT the instrument's detector head should: 1. be located out of any turbulent air currents -- preferably several inches to a foot or more from any opening, 2. recycle times of the detector temperature reference source when mounted in the aircraft should be approximately the same as those observed in the laboratory; however, small fluctuations in the temperature record have been observed when the detector was placed near a source of turbulence, even though recycle times were approximately the same as experienced in the laboratory, 3. be loosely shock-mounted and the console be provided with a shock pad.

Interference from UHF transmitters has been observed, and when near some military installations or ships, an increase in erratic behavior of the IRT has been noted. On some occasions a shifting aircraft vibration frequency, such as a change in propeller pitch, appears to affect the IRT. This sometimes can be eliminated by damping the instrument case.

Haze observations indicate a decrease in temperature of an estimated  $0.68^{\circ}$  F. per 1000 feet at a surface visibility estimate of six miles. Low, thin scattered stratus appears not to have an observable effect on the airborne IRT readout.

Rain showers sometimes cause a reduction in IRT temperature readout. The effect probably is dependent upon the relationship of the rain temperature to the water temperature.

Air temperature isotherms from observations made at 500' M.S.L. in most areas appear not to parallel sea surface isotherms. IRT isotherms sometimes appear to parallel wind flow patterns around prominent geographical points of the mainland as observed off Pt. Conception and Santa Barbara channel islands. Parallel isotherm and wind flow patterns appear more evident in areas having higher wind velocities. In offshore areas there appears little paralleling of wind flow and isotherms.

#### REFERENCES

Anon.

1962. Application Note 14-0300-1, Sea Surface Temperature Plotting with Model 14-312 Radiometer, Barnes Engineering Company. Stamford, Conn.. 5 p.

Anon.

1963. Pacific Coast continental shelf temperature survey, southern area, November. Correction values for infrared sea surface charts - August to October 1963. Tiburon Marine Laboratory, Tiburon, California, 1 p.

Clark, John and J. L. Frank

1963. Infrared measurements of sea surface temperatures. Undersea Technology, October, vol. 10, No. 4, pp. 20-23.

Ewing, Gifford C.

1952. Low-level Marine Aerology, University of California, Scripps Inst. of Oceanography, Progress Report No. 7, Contract No. AF 19 (122)-413, S.I.O. Ref. 52-53, 10 Oct. 52, pp. 2-5.

Ewing, Gifford C. and E. D. McAlister

1960. On the thermal boundary layer of the ocean. Science, vol. 131, No. 3410, pp. 1374-1376.

Frank, Sidney R.

1962. Operation C.O.W. Proceedings of the first interindustrial oceanographic symposium. June 14, 1962, Burbank, California, published by Lockheed Aircraft Corporation, pp. 2-5.

Hildreth, William H., Jr.

1962. Interaction of the ocean and atmosphere. Proceedings of the first interindustrial oceanographic symposium, Burbank, California, published by Lockheed Aircraft Corporation, pp. 6-11, June 14, 1962.

Weiss, M.

1962. Sea and earth surface temperature measurement using infrared. Second symposium on remote sensing of environment. Oct. 15-17, 1962, University of Michigan, Ann Arbor, Michigan.

# SLITHERING ISOTHERMS AND THERMAL FRONTS ON THE OCEAN SURFACE

by G. C. Ewing, Scripps Institution of Oceanography,  
University of California, San Diego

Compared to the sensible temperature measured by mercury thermometers in conventional bucket samples, the equivalent blackbody temperature of the sea surface measured from a low-flying aircraft is distorted to a variable degree by: (1) a component reflected from the sky, always cold, and (2) the deviations of the thermal boundary layer, usually cool at night and warm in the daytime (References 1, 2).

The distortion due to the reflection depends on two parameters: (a) The coefficient of reflection which varies according to Snell's Law with the angle of incidence at the water surface of the rays reaching the radiometer. At normal incidence the coefficient is roughly .02, increasing to about .06 at  $60^\circ$ . (b) The equivalent blackbody temperature of the sky varies with zenith angle and azimuth. On a clear night the zenith may be  $50^\circ$  Kelvin colder than the horizon and the temperature  $30^\circ$  above the horizon may vary  $10^\circ$  from east to west, being warmest in the west during the hours after sunset. The thermal 'correction' to be applied to the infrared temperature to offset the contribution of the sky depends therefore on the 'look angle' and the prevailing sky conditions. It may vary from 0 under a cloudy sky to  $1^\circ$  Kelvin on a clear day or night. It is always positive, that is, it is to be added to the equivalent temperature measured by the radiometer.

The correction for the distortion due to thermal boundary layer is sometimes positive and sometimes negative, depending on whether the heat flux is directed upwards out of the water or downwards. During daylight hours the sea is usually being heated from above so that the heat flux is downward. The thermal boundary layer is, therefore, warm and the correction to the infrared apparent temperature is negative. At night the sea is usually cooling and the appropriate correction is positive. In each case the magnitude may be as much as  $0.5^\circ$  Kelvin.

The foregoing may be summarized as follows:

Table for Correction of Infrared to Equivalent Bucket Temperature

	<u>Day</u>	<u>Night</u>
Sky correction	0 to + $1.0^\circ$ K	0 to + $1.0^\circ$ K
Boundary layer correction	<u>0 to - <math>0.5^\circ</math>K</u>	<u>0 to + <math>0.5^\circ</math>K</u>
Total Correction	- $0.5^\circ$ to $1.0^\circ$ K	0 to + $1.5^\circ$ K

As a general rule of thumb, an over-all correction of  $1^\circ$  K may be representative.



The foregoing uncertainty introduces a formidable obstacle to the determination of absolute temperatures of the sea surface from aircraft using only infrared techniques. On a particular occasion the uncertainty could be somewhat reduced either by estimating a correction, or by directly measuring both the infrared signal from the portion of the sky from which the reflected rays received by the radiometer originate and the sense and amount of the heat flux across the thermal boundary layer. By sufficient effort, the correction might be defined to within  $0.5^{\circ}$  K.

What such uncertainty means in terms of displacement of the isotherms on a map of the sea surface depends on the area considered. On the West Coast, where the horizontal gradient of surface temperature may be as small as  $1^{\circ}$  K per degree of latitude, the displacement of a given isotherm might, under severe conditions, be as great as 90 miles. On the other hand, in a region where the horizontal gradient is very acute as along the western boundary of the Gulf Stream, the displacement would be negligible. Since the correction is altered by changes in the evaporation rate and the pattern of clouds, the apparent isotherms as seen by radiometer must slither about the ocean surface like monstrous sea snakes. Any representation of their configuration is in the nature of a snap-shot of an ever changing scene.

In any case, the horizontal temperature gradients are much more precisely defined than is the absolute value of the particular isotherms. Thus, the spread or clumping of the isotherms is correctly shown without regard to the temperature labels attached. For use in marine biology and for many aspects of physical oceanography, the location of these transition boundaries may be far more significant than the absolute values of the temperature. For example, it is well known that heavy fish populations occur in the neighborhood of these boundaries. This may be due to the 'snow fence' effect of the thermal barrier, or it may be the result of food concentration in regions of horizontal convergence (Reference 3). Examples of areas with high horizontal gradients that are highly productive are: the western edge of the Gulf Stream, the edge of the Kuroshio, the 'front' across the entrance to the Gulf of California, and the region of the Antarctic convergence.

It is therefore concluded that thermal maps of the sea surface made from infrared data collected periodically from low-flying aircraft will be highly useful to marine biologists and physical oceanographers, regardless of the difficulties of assigning absolute values to the specific isotherms. As the state-of-the-art progresses, the real temperature will doubtless be better and better defined.

#### REFERENCES

1. Ewing, G. C., and McAlister, E. D., 1960, 'On the Thermal Boundary Layer of the Ocean', Science, vol. 131, No. 3410, pp 1374 - 1376.
2. McAlister, E. D., 1964, 'Infrared-Optical Techniques Applied to Oceanography: 1. Measurement of Total Heat Flow from the Sea Surface', Journal of Applied Optics, vol. 3, No. 5, May 1964, pp 609 - 611.
3. Hardy, C., 'The Open Sea', Collins, London, 1956, pp 335.

# SOME FACTORS INFLUENCING THE SKIN-TEMPERATURE OF THE SEA AND ITS MEASUREMENT BY INFRARED THERMOMETER

by Guy A. Franceschini, Department of Oceanography and Meteorology,  
Texas A & M University, College Station

## INTRODUCTION

This is intended to be a preliminary and qualitative review-note on factors influencing IRT readings taken of the sea surface. Related observations made at sea are appended.

In general, IRT readings may be based on an absolute calibration of the instrument performed under laboratory-control, or they may be based on secondary field calibrations performed repeatedly *in situ*. In the former case, a blackbody cavity at a known temperature may be employed as the reference, whereas in the latter instance a suitable target, e.g., a well stirred bucket of water at known temperature may be used. There are advantages to each method depending on whether or not: 1) the optical properties of the surface are known, 2) the measuring system exhibits stability. In practice a combination of the two methods may be desirable.

Evidence obtained within the last twenty years, and to a greater extent in the last five years, definitely indicates that the temperature of a thin layer of water at the surface is usually different from that obtained by standard measuring techniques, i.e., bucket, intake, or towed thermistor. The data tabulations in the Appendix show these differences may be positive or negative depending primarily on meteorological factors. The unusually large positive differences (skin warmer) are found in and near areas of active rainfall. From a theoretical standpoint these differences, both positive and negative, are expected since all energy interactions with the atmosphere occur at the surface. Evidence and theory indicate the existence of a thin surface layer which, of necessity, constrains and is influenced by these interactions. Because of this mutual dependence, it is necessary to know the "what, where, how, and why" of skin-surface temperatures.

Since the size of this surface film is usually rather small, e.g., tenths of millimeters, the near-ideal way to determine its temperature is with a remote sensing radiation instrument--the IRT. Advantages of such a device are well known. Further, if the relationship between skin-temperature and sub-surface temperature is known, IRT readings may be used to determine sub-surface temperatures, i.e., temperature of water in the mixed layer immediately below the surface.

## FACTORS INFLUENCING SURFACE TEMPERATURE

If we neglect chemical and biological reactions, the temperature of the surface film depends on exchanges of energy with the atmosphere and the underlying water, i.e., transfers across the boundaries of the film. The process of concern are:

- 1 - radiation (water, water vapor, CO<sub>2</sub>, clouds)
- 2 - sensible heat transfer (water, air)
- 3 - latent heat transfer (air)
- 4 - precipitation
- 5 - wind mixing

## Radiation

Gains by the surface are received from atmospheric constituents including clouds. Emissions from these sources depend on their temperatures, amounts, and their effective emissivities. Losses from the surface similarly depend on the surface temperature and emissivity. Ordinarily, natural surfaces have emissivities near unity in the infrared portion of the spectrum. However, the value for water (and most natural bodies) appears to lie between 0.96 and 0.98. (Consideration should be given to this factor especially if one employs an IRT which has been calibrated with a blackbody reference). Consequently, to assess radiation exchanges, values of surface temperature, air temperature and humidity, cloud amount and temperatures, and emissivities of radiating bodies must be known. These fluxes may be measured, of course.

## Sensible Heat Transfer

The transfer of sensible heat to and from the surface film may occur across either boundary. The process, usually called conduction or convection (eddy thermal conduction), results as a consequence of a temperature gradient, and is enhanced by motion or mixing of the fluids. Consequently, the exchange between sea and air is related to the air and surface temperature difference as well as wind speed. Transfers across the bottom boundary of the surface film similarly depend on the temperature difference between surface and sub-surface water as well as water motion. Usually the latter is related to wind speed. Hence a knowledge of the distribution of these parameters is needed for estimating the associated transfers. Unfortunately, the transfer coefficients are not simple constants and the problem is not completely solved. Inherent in the transfer within the fluid is the process of radiation. Presumably the coefficient of thermal transfer includes this effect, but the problem needs further study.

## Latent Heat Transfer

This process, which involves the change of phase of water, is related primarily to the gradient of water vapor above the surface. As with sensible heat transfer, it is enhanced by mixing and the increase of water surface, and consequently is related to wind speed as well as thermal instability. Here, again, the transfer coefficients are not well established, but an understanding of the process at sea may be improved if the involved parameters are known. Since the vapor pressure of the water surface is involved, and since this parameter depends on the surface-skin temperature, the mutual dependence of process and surface temperature



is again indicated. The process of latent heat transfer plays a dominant role in determining the temperature of the surface film.

### Precipitation

A change of temperature of the surface film may be brought about by the addition of colder or warmer precipitation. The magnitude of this change depends on the phase of the precipitation, the initial temperatures of surface and precipitation and the equivalent depth of both constituents involved in the final mixture. The depth of sea water involved is influenced by the degree of mixing. Hence, factors which cause mixing, i.e., wind action, mechanical effects of the falling substance, and unstable stratification, are critical. The latter factor depends on fluid viscosity and on vertical density differences which in turn depend on differences in temperature and salinity. The largest deviations observed between skin and "bucket" temperatures occur in areas of active precipitation. These deviations may amount to several degrees Celsius. (See appended data). The conversion of kinetic energy of falling rain into thermal energy is assumed to have little influence on the resulting surface temperature.

### Wind Mixing

As mentioned in the preceding paragraphs, wind is directly involved in several of the processes considered. Since it creates a stirring of the water (momentum transfer) it also leads to the generation of heat due to internal friction, i.e., viscosity. It is anticipated that this effect may be minor when compared with effects of other processes.

From the above it is apparent that all meteorological factors normally observed influence the temperature of the surface. The degree of influence must be determined for a better understanding of the problem.

## METEOROLOGICAL FACTORS INFLUENCING IRT READINGS

A brief review of factors influencing IRT readings is beyond the scope of this note. However, since the device senses ir-radiation, a comment in this regard may be in order.

Since we are dealing with an IRT which remotely senses radiation over the limited waveband of 8-13 microns, and since optical paths to the target surface are relatively short (usually less than 1,000 ft), the influence of atmospheric water vapor and carbon dioxide will be assumed negligible. Also, since penetration distance of ir-radiation within water is small, i.e., tenths of millimeters, concern will be with the surface film from which upward directed radiation emanates. Consequently, the effective temperature of this film will be referred to as the surface temperature.

Consider the upward directed stream of long-wave radiation above the ocean surface under an overcast sky. In particular, consider the radiation between 8-13 microns. If we



assume a simple situation in which the atmosphere is transparent to this radiation, and emissions and reflections are isotropic, we may express this upward stream, F, as

$$F = E_o + r_o (E_c + r_c F) \quad (1)$$

where:

- $E_o$  = emitted flux from the surface
- $r_o$  = reflectivity of the surface
- $E_c$  = emitted flux from the cloud base
- $r_c$  = reflectivity of the cloud base

Quantities refer to the radiation 8-13 microns. The second quantity on the right of (1) represents the fraction of the downward stream which is reflected upward by the surface. Equation (1) may be solved for F giving

$$F = (E_o + r_o E_c) / (1 - r_o r_c) \quad (2)$$

If we now let:

$$\begin{aligned} E_o &= (1 - r_o) \Delta\theta_o \sigma T_o^4 \\ E_c &= (1 - r_c) \Delta\theta_c \sigma T_o^4 \\ F &= \Delta\theta \sigma T^4 \end{aligned} \quad (3)$$

Where:

- $(1 - r_o)$  = emissivity of the surface
- $(1 - r_c)$  = emissivity of cloud base
- $\Delta\theta_i$  = fractional black body flux between 8-13 microns
- $T_o$  = surface temperature ( $^{\circ}$ K)
- $T_c$  = surface temperature of cloud base ( $^{\circ}$ K)
- T = blackbody temperature associated with the upward flux F
- $\sigma$  = Stefan-Boltzmann constant

We may rewrite (2) as

$$F = \Delta\theta \sigma T^4 = \left[ (1-r_o) \Delta\theta_o T_o^4 \sigma + r_o (1-r_c) \Delta\theta_c \sigma T_c^4 \right] / (1-r_o r_c) \quad (4)$$

If the instrument which senses  $F$  is calibrated with reference to a blackbody cavity, it will assign the value  $T$  to the surface. Equation (4) shows, however, that  $T$  will be equal to  $T_o$  only in special cases. For example:

- a. if  $T_c = T_o$  then  $T = T_o$
- b. if  $r_o = 0$  then  $T = T_o$
- c. if the sky is clear then  $T < T_o$
- d. if  $r_o = r_c$ 
  1. for  $T_c < T_o$ ,  $T < T_o$
  2. for  $T_c > T_o$ ,  $T > T_o$

Consequently, appreciable error may result especially under clear sky conditions, e.g.,  $1^\circ\text{C}$ . Use of (4) is possible if cloud base temperature and reflectivities are known. Ordinarily, surface and cloud reflectivity over the 8-15 micron wave band may be taken as 0.014 for normal incidence. On the other hand, if calibration of the IRT is done in the field *in situ*, as mentioned earlier, these difficulties are eliminated. The procedure would be time consuming but fruitful. As a point of interest, if two IRT's were employed simultaneously, one lab-calibrated while the other was field calibrated, it may be possible to estimate the reflectivity of the water surface over the wave band considered. This should also be possible with one lab-calibrated IRT in a controlled experiment where water temperature is known and a plate of known optical properties and temperature is used to simulate the cloud base.

#### OTHER COMMENTS

It is hoped that the above discussion may give some guidance in considerations of the nature of what an IRT measures. If reliable IRT readings are made, it is likely they may be correlated with sub-surface temperatures under varying but known ambient conditions. Consequently, if one water temperature is known the other may be estimated. From the standpoint of air-sea interactions as well as of operational needs, this would appear desirable. Empirical equations of this type have been obtained for this purpose (R. D. Boudreau, M.S. Thesis, Dept. Oceanography and Meteorology, Texas A&M University).

## APPENDIX

Observations taken on a traverse  
between Africa and Antarctica  
during the period 16-27 March 1963  
aboard the M/V OB  
(8th Soviet Antarctic Expedition)

Tables attached hereto present pertinent data obtained on a traverse between Antarctica and the southern tip of Africa. Observations were made aboard the USSR vessel M/V OB during the 8th Soviet Antarctic Expedition. Participation of the writer was under the US/USSR Scientists Exchange Program of the NAS and sponsored by the NSF. Standard weather observations were made by host personnel. Atmospheric moisture measurements were not available. In the table, standard coding and symbols are employed. In the column labeled "Sky" the first digit preceding the slant (/) represents total sky coverage in eights. The remaining 5 digits represent the standard cloud group. The values under " $T_a$ " represent air temperature at about 50 feet above the water. " $T_w$ " values are water temperatures determined by a towed thermistor; " $T_o$ " values are surface water temperatures made by a shielded, field-calibrated Barnes IRT, Model IT-1. The 4-digit numbers under remarks are standard wave groups without the initial designator, 1.

16 March 1963

Time GMT	Lat °S	Long °E	Sky	Wea Vsby	Wind dd/k	Temp °C			Remarks (surface, waves, etc.)
						T <sub>a</sub>	T <sub>w</sub>	T <sub>o</sub>	
00	69.9	12.7							On coast
01									
02									
03									
04									
05									
06									
07									
08									
09									
10									
11	69.9	12.7	0ci	97 DS					Snow on shelf ice; slush -5.1°C; snow -15.4°C
12									On coast (Novolazarevskaya); snow -16.2°C
13									Snow -15.9°C
14									Snow -15.1°C
15									Snow -16.2°C
16									Snow -16.9°C
17									Snow -17.6°C
18									Snow -18.2°C
19									Snow -18.7°C
20			O (ac to N)	98	SW 15				Snow -19.2°C; snow on shelf ice
21									Snow -19.6°C
22									Snow -20.2°C
23									Snow -20.6°C
24			Leaving coast (Novolazarevskaya)						Snow -21.0°C; slush -5.9°C
			Breaking through snow covered sea ice						-3.2



17 March 1963

Time CMT	Lat °S	Long °E	Sky	Wea Vsby	Wind dd/k	Temp °C			Remarks (surface, waves, etc.)
						T <sub>a</sub>	T <sub>w</sub>	T <sub>o</sub>	
00									Snow -21.0°C; slush -5.9°C
01									Slush -7.9°C
02									Slush -8.7°C
03									Slush -8.8°C
04									Slush -9.2°C
05									Slush -11.3°C
06	69.1	14.3	⊕sc (OS)	98					Snow -15.4°C; slush -9.9°C
07									Snow -13.0°C; slush -6.5°C
08			⊕sc (OS)	98	W12				Snow -10.1°C; pack ice
09	68.9	14.4	⊕sc	98(S--)		-8.7			Snow -9.4°C
10									Snow -8.0°C slush -5.8°C
11									Snow -6.8°C
12	68.5	14.7	⊕scS, fc	98	WSW20				⊕ slush (T <sub>o</sub> = -4.9°C), small pancakes;
13			⊕cu			-5.9			3235, 2720. 13:00 slush (T <sub>o</sub> = -3.1°C)
14									
15	68.2	16.2	⊕cu		W25				Water, caps, no ice, no slush, 2838
16									
17	68.1	17.4	⊕cu		W35				2838
18									
19									
20									(rough all night)
21									
22	67.7	20.1							
23									
24	67.6	21.0	6/655xx	98022	35/20	-3.9	-1.3	-1.9	

18 March 1963

Time GMT	Lat °S	Long °E	Sky	Wea Vsby	Wind dd/k	Temp °C			Remarks (surface, waves, etc.)
						T <sub>a</sub>	T <sub>w</sub>	T <sub>o</sub>	
00	67.6	21.3	6/655xx	98022	35/20	-3.9	-1.3	-1.9	Water
01							-0.9	-1.9	
02							-0.9	-1.8	
03							-1.1	-1.6	
04							-1.0	-1.8	
05							-0.9	-1.8	
06	67.2	24.6	7/755xx	98022	25/24	-2.8	-0.8	-1.6	Caps, streaks; 2732, 2737
07							-0.6	-1.4	
08			⊕sc	98	W20	-3.2	-0.9	-1.4	
09	66.9	26.4					-0.7	-1.4	
10							-0.7	-1.4	
11							-0.7	-1.2	
12	66.8	28.0	6/35508	98022	20/32	-2.4	-0.6	-1.5	
13							-0.6	-1.5	
14							-0.5	-1.4	
15							-0.5	-1.4	
16	66.1	27.3	⊕ci⊕ac⊕cu				-0.4	-1.2	
17							-0.5	-1.1	
18	65.8	26.3	8/8052x	97022	30/24	-3.9	-0.5	-0.8	No caps; 2836
19							-0.6	-0.9	
20							-0.6	-1.1	
21							-0.6	-0.9	
22							-0.5	-1.0	
23							-0.4	-1.1	
24	65.2	23.8	8/8042x	97022	29/20	+0.4	-0.3	-1.1	

19 March 1963

Time GMT	Lat °S	Long °E	Sky	Wea Vsby	Wind dd/k	Temp °C			Remarks (surface, waves, etc.)
						T <sub>a</sub>	T <sub>w</sub>	T <sub>o</sub>	
00	65.2	23.8	8/8042x	97022	29/20	+0.4	-0.3	-1.1	
01							-0.2	-1.1	
02							-0.2	-0.8	
03							-0.3	-0.4	
04	65.0	22.0	⊕asac⊖sc	98				-0.6	
05			⊕asac⊖sc	98	W12	-0.4		-1.0	On station, no caps 05:40-50, 3S- -, ⊖ caps; 3023
06	65.4	22.0	8/8042x	96022	25/12	+0.2		-0.1	Blue water
07								-0.8	
08			⊕sc	98				-1.1	BINOVC, few caps
09							-0.2	-0.3	Underway
10	64.8	22.2	⊕ac⊖sc	98	W12	+0.3	-0.8	-0.6	Few caps; 2533
11							-0.8	-0.7	
12	64.3	22.2					-0.7	-0.4	
13			⊕asac⊖sc	98	W12	0.0	-0.8	-0.4	13:30, nice blue, no caps; 2523, 3033
14	63.9	22.1	obsed	94FL-			-0.8	-0.4	Fog b13:40 GMT, e14:30 GMT
15							-0.7	-0.2	
16	63.4	22.1	⊕asac⊖sc	98RW-	WNW8	-0.4	-0.6	+0.1	Cu cong, no caps; 2533, 3022
17							-0.6	-0.2	
18	63.0	22.1	⊕sc <u>cu</u>	RW-	N5	-0.8	-0.6	-0.4	Smooth; 2533
19							+0.3	-0.4	
20							+0.3	-0.4	
21							+0.2	0.0	
22							+0.3	+0.3	
23	61.9	22.2						+0.7	On station
24								+0.4	

20 March 1963

Time GMT	Lat ° S	Long ° E	Sky	Wea Vsby	Wind dd/k	T <sub>a</sub>	Temp °C			Remarks (surface, waves, etc.)
							T <sub>w</sub>	T <sub>o</sub>	T <sub>o</sub>	
00								+0.4		On station
01								-0.3		
02								-0.7		
03								-0.2		Off station 03:30 GMT
04	61.8	22.9					+0.3	-0.2		
05			obscd	93FSW			+0.3	-0.2		
06	61.4	21.9					+0.2	+0.1		
07			obscd	93FSW	NNE8	0.6	0.0	+0.1		Ocnl cap; 0223
08							+0.1	+0.2		Wet snow clusters, d = 1 in.
09							+0.9	-0.3		
10	60.7	21.8					+0.8	-0.3		
11							+0.3	-0.1		
12	60.2	21.8					+0.3	-0.1		
13			obscd	92FL	NW12	0.7	+0.4	+0.1		Few caps, ocnl spray; 3346, 3322
14	59.8	21.8					+0.7	+0.8		Small berg half mile to starboard
15			obscd	92FSW			+0.7	+0.6		Caps incrg, wet snow
16	59.4	21.7	W⊕st	95F	NW15		+0.6	+0.2		Caps incrg, foam
17							+0.6	-0.1		
18	58.8	21.7	⊕as⊕st		NW15	0.4	+0.6	+0.2		Ocnl caps, little foam; 3222, 3245
19								-0.3		18:15 GMT on station
20								0.0		
21								+0.2		
22								+0.4		
23								+0.3		Off station 23:30 GMT
24	58.8	21.7					+0.6	-0.2		



21 March 1963

Time GMT	Lat °S	Long °E	Sky	Wea Vsby	Wind dd/k	T <sub>a</sub>	Temp T <sub>w</sub>	°C T <sub>o</sub>	Remarks (surface, waves, etc.)
00	58.8	21.7					0.6	-0.2	
01							0.7	-0.3	
02							0.5	-0.2	
03							0.6	0.0	
04							0.9	0.6	
05							0.8	0.7	Blue, few caps
06	57.6	21.5	⊖ac⊖sc	98	NW12	0.2	1.0	0.2	Few bergs, RW E; 3222, 3244
07							1.2	0.9	
08	57.1	21.5	⊖ac⊖sc	98			1.1	0.7	⊖cu cong, sctd shwrs
09							0.9	0.1	
10	56.7	21.4					0.9	0.3	Ocnl snow flake, ocnl cap
11							0.9	0.3	
12	56.2	21.4	⊖asac	98SW-	N4	0.6	0.8	0.8	Bergs, smooth, no caps
13	56.0	21.4	⊖asac⊖sc	98S-			0.9	0.7	On station 13:10 GMT
14								0.1	
15			⊖as⊖st	98S--	S8	0.7		1.0	Blue, ripples, no caps; 3234
16							1.2	1.6	Off station 15:35 GMT
17							0.8	0.9	
18	55.5	21.3	⊖ns	95S	S12	0.6	1.0	0.9	Slight roll; 3234
19							1.0	0.7	
20							1.0	0.6	
21							1.3	0.9	
22							1.0	1.1	
23							1.1	1.1	
24	54.1	21.2	8/87x2x	94737	20/26	0.9	1.1	1.2	

22 March 1963

Time GMT	Lat °S	Long °E	Sky	Wea Vsby	Wind dd/k	Temp °C		Remarks (surface, waves, etc.)	
						T <sub>a</sub>	T <sub>w</sub>		
00	54.1	21.2	8/87x2x	97437	20/26	0.9	1.1	1.2	
01							1.2	1.4	
02							1.0	0.8	
03							1.1	1.0	
04							1.3	1.2	
05	53.1	21.4	⊕sccu	97RW-	SW25		1.4	1.3	1 tabular berg, many caps, foam & streaks; 2346, 2342 On station 05:35 GMT RW 05:50 GMT
06	52.9	21.2	8/8722x	94717	17/44	1.3		1.2	
07								1.3	
08								1.5	Underway 8:30 GMT
09	52.8	21.1					1.5	1.8	
10	52.6	21.1	⊕sccu		WSW25		1.2	1.2	Caps; 7351, 2323
11			obsd	94SW			1.4	2.2	Soft grains - ended 11:20 GMT
12	52.1	21.1	8/5622x	97027	22/38	1.0	1.3	1.5	Caps, etc 7351, 2323
13							1.5	1.5	
14	51.6	21.1	obsd	94SW			2.0	2.0	Wet flakes
15							2.6	2.0	
16	51.2	21.1	obsd	94S	WSW30		1.1	2.4	Blue, caps, much foam: 2323, 7343
17			⊕ac⊕sc				2.4	1.9	2323, 7343
18	50.9	21.1	8/87x2x	97027	22/46	0.9	2.3	1.8	On station 18:35 GMT
19								1.6	
20								1.1	
21			⊕asac		SW/40		2.3	1.8	Caps, foam: 2322, 2336
22	50.6	21.2					2.5	2.6	Off station 21:32 GMT
23							3.3	3.2	
24	50.2	21.3	0/00900	98021	24/48	2.6	3.3	2.6	

23 March 1963

Time GMT	Lat °S	Long °E	Sky	Wea Vsby	Wind dd/k	Temp °C			Remarks (surface, waves, etc.)
						T <sub>a</sub>	T <sub>w</sub>	T <sub>o</sub>	
00	50.2	21.3	0/00900	98021	24/48	2.6	3.3	2.6	
01							3.2	2.7	
02	49.7	21.3					3.4	3.4	
03								4.1	On station
04								4.0	
05			0ci0ac	98	WNNW12			4.2	Blue, few caps
06	49.7	21.2	8/855xx	98032	30/30	4.1	3.5	3.7	Off station; 2423, 2436
07			0ac0sc	98	WNNW12	4.2	4.4	4.1	Caps, foam; 2722, 2736
08	49.3	21.3	0ac0sc		NW15		4.4	4.7	Blue, caps, foam, spray; 3123, 3147
09							4.5	4.6	
10	48.8	21.2	0as	R-			5.0	5.5	
11							5.2	5.9	
12	48.4	21.2	8/8052x	95636	32/38	6.4	5.3	5.8	Bow spray
13							5.7	6.5	
14	48.0	21.2					6.0	6.6	
15			obsed	93FR	NNW30		6.9	7.2	3334, 5343
16	47.6	21.2					7.1	7.7	
17				R			7.6	8.2	
18	47.3	21.2	8/87x2x	92616	32/46	8.8	7.9	9.2	
19							7.8	8.4	
20	47.0	21.2					9.9	8.7	On station
21							10.0	8.6	
22							7.9	8.8	Off station
23	46.8	21.2					8.7	9.2	
24	46.6	21.2	8/87x2x	94636	31/58	8.6	9.0	9.8	

24 March 1963

Time GMT	Lat °S	Long °E	Sky	Wea Vsby	Wind dd/k	T <sub>a</sub>	Temp °C		Remarks (surface, waves, etc.)
							T <sub>w</sub>	T <sub>o</sub>	
00	46.6	21.2	8/87x2x	94636	31/58	8.6	9.0	9.8	
01							8.9	9.8	
02							9.1	9.7	
03							9.9	9.9	
04							10.6	10.2	
05			☉ns☉sc	96R			10.4	10.5	
06	45.5	21.2	8/8722x	95616	22/34	8.3	10.4	12.1	06:30: T <sub>w</sub> = 12.9°C; T <sub>o</sub> = 14.3°C
07							12.9	14.5	
08	45.1	21.3		R			13.0	14.2	
09							12.4	13.9	09:50: T <sub>w</sub> = 12.5°C; T <sub>o</sub> = 14.3°C
10	44.6	21.3		R-			15.5	18.3	
11							15.6	18.8	
12	44.2	21.3	8/862xx	93614	24/24	10.8	13.5	19.4	
13	44.0	21.3					13.3	19.3	On station 13:50
14				R				19.1	14:45: T <sub>o</sub> = 14.2°C
15								14.3	
16			☉as☉sc	96R		10.9		15.3	Few caps; xx59
17								15.6	
18	44.0	21.2	8/862xx	94636	14/14	9.8		15.9	Off station 18:50
19	43.9	21.3					12.2	15.9	
20							13.8	16.2	
21							14.5	16.3	
22							16.0	17.2	
23							15.5	17.4	
24	42.8	21.2	8/864xx	96026	31/36	15.5	13.8	15.8	



25 March 1963

Time GMT	Lat °S	Long °E	Sky	Wea Vsby	Wind dd/k	T <sub>a</sub>	Temp °C			Remarks (surface, waves, etc.)
							T <sub>w</sub>	T <sub>o</sub>	T <sub>o</sub>	
00	42.8	21.2	8/864xx	96026	31/36	15.5	13.8	15.8		
01							12.5	13.3		
02							15.5	16.6		
03							15.0	17.3		
04	42.0	21.2					15.5	17.9		On station 04:55
05			⊖ac⊖-⊖sc 98		NW20	17.2	15.2	17.7		
06			7/38440	98011	31/24	17.1	16.5	17.8		Green, caps; 3245
07	41.8	21.2					18.0	19.3		Off station 06:30
08	41.6	21.2	⊖ac	98	NW20		18.0	19.6		⊖sc to S
09							20.5	20.0		
10	41.2	21.2					22.4	19.6		
11							15.0	17.4		
12	40.7	20.3	4/32502	98101	33/18	21.8	21.0	21.0		
13							19.5	22.5		
14			obscd	93FR	NW15		21.0	23.4		3122
15	40.0	21.0	⊖sc				23.5	24.0		On station 15:25 AC vsbl through brks
16										
17										
18			0/00900	98016	23/24	15.2				
19								22.1		
20								22.0		
21								22.1		Off station
22								22.2		
23	40.0	21.0						21.1		
24	M	M								21.8

26 March 1963

Time GMT	Lat °S	Long °E	Sky	Wea Vsby	Wind dd/k	T <sub>a</sub>	Temp °C	Remarks (surface, waves, etc.)
							T <sub>w</sub> T <sub>o</sub>	
00	M	M					21.8	
01	39.8	20.9					22.0 20.4	
02							21.5 21.9	
03							18.0	
04							15.5	
05	38.8	20.4	☉sc				15.5	Blue, few caps; On station 05:10 2 1yrs sc
06			7/755xx	98022	18/30	15.8	20.6	Blue, few caps; 2355
07							21.0	
08							15.4 20.9	Off station 08:45
09			☉sc☉cu		SSW15	15.7	15.4 20.4	Blue, few caps; 2346, 2322
10	38.4	20.3	☉sc☉cu			13.0	19.8	
11						17.9	20.3	
12	38.1	20.0	5/51500	98022	17/32	15.4	18.4 21.3	
13							17.3 22.8	
14	37.7	19.8	☉sc☉cu		SSW20	16.2	17.3 23.9	RWUN semicircle; green, caps, foam; 2022, 2045; 15:34: T <sub>w</sub> = 14.0°C,
15			97RW-				17.5 23.0	T <sub>o</sub> = 18.9°C; 16:00: 2049, 2023
16	37.3	19.6				14.5	19.8	
17						18.0	18.8	
18	36.9	19.3	6/64500	98022	16/24	16.8	17.0 18.3	
19							18.3	On station 19:25
20			☉sc		S20	16.6	18.6	Few caps
21							18.8	
22							18.8	
23	36.6	19.1				16.0	18.6	Off station
24	36.3	18.9	0/00900	98010	12/22	17.3	17.6 18.1	

27 March 1963

Time GMT	Lat °S	Long °E	Sky	Wea Vsbby	Wind dd/k	T <sub>a</sub>	Temp °C		Remarks (surface, waves, etc.)
							T <sub>w</sub>	T <sub>o</sub>	
00	36.3	18.9	0/00900	98010	12/22	17.3	17.6	19.4	
01							21.5	23.1	
02							20.0	21.4	
03							15.8	18.6	
04							17.4	17.0	
05							13.2	14.4	
06	35.1	18.3	5/54500	98021	16/34	16.2	14.4	15.4	Ocnl spray, green, caps, foam, streaks;
07			0sc	98	ENE20	16.3	15.6	16.8	0723, 1435
08							15.6	17.1	
09					ESE25		10.5	14.7	1437, 1223
10								12.4	
11			0ac	98H	SE40	15.4		12.4	Green, caps, streaks, spray; 1437, 1423
12	34.2	18.2	0/00900	97020	15/36	15.2		11.7	
13			O	10 H	SE25	15.8		11.1	Green, caps, some foam; 1422; (ac N-NE)
14								10.2	13:00 approx. 5 mi WSW CPT
15								11.2	Heading into port
16								11.0	
17								13.1	
18								13.6	
19	Docked	- CPT			SE8	19.4		13.4	Docked 19:15 GMT

# USE OF THE BARNES MODEL 14-320 AIRBORNE RADIATION THERMOMETER IN AERIAL SURVEYS OVER THE NORTH ATLANTIC

by Robert A. Peloquin, John C. Wilkerson and George L. Hanssen,  
U. S. Naval Oceanographic Office, Washington, D. C.

## INTRODUCTION

Synoptic analysis, an important tool in forecasting vertical and horizontal thermal structure of the ocean and their effects on ASW equipment performance, is being developed for operational use by the Navy under the Antisubmarine Warfare Environmental Prediction System (ASWEPS). The airborne radiation thermometer (ART), Barnes model 14-320, has been used experimentally by the U. S. Naval Oceanographic Office to determine the value of infrared sea surface temperature measurements as synoptic information.

ART data are being used in surface temperature analyses and in construction of sea surface temperature charts. The instrument, developed by the Barnes Engineering Company of Stamford, Connecticut, is packaged in a console designed to fit over the camera hatch of a P2V. The ART measures sea surface temperature over a range of  $-2^{\circ}$  to  $+35^{\circ}\text{C}$  with an accuracy of  $\pm 0.2^{\circ}$ .

## TECHNICAL ASPECTS OF THE ART

### Instrument Accuracy

In the laboratory, the ART has consistently demonstrated ability to measure water temperature to within  $\pm 0.2^{\circ}\text{C}$ . A temperature-controlled water bath and a mercury thermometer are used for calibration. Calibration is a long process which can normally be performed in one day. The field accuracy of the ART is more difficult to determine. The ART measures the temperature of a 0.01 mm layer at the surface. At present, there are no standards which can successfully measure this layer. Comparative measurements with thermistors, bucket thermometers, and reversing thermometers, on some occasions, have been within  $0.5^{\circ}\text{C}$ . On other occasions, as much as  $3.0^{\circ}\text{C}$  deviation has been noted. Environmental influences may have very pronounced effects on infrared measurements. Of the comparative measurements made to date, the best agreement was obtained in the Tongue of the Ocean and Bermuda areas, where the air-sea temperature difference was close to zero. The largest discrepancies occurred in the Gulf Stream when the air-sea temperature difference was of the order of  $10^{\circ}\text{C}$ .

The instrument is restricted to fair-weather operation. Precipitation, low cloud ceilings, haze, and sea states of 6 or higher hamper ART operations.



## Laboratory Tests

Isolation of surface noise from instrument noise in the flight record has been a problem. The model 14-320 ART is not designed to military specifications and responds unfavorably to shock and air turbulence. The noise can be reduced to a tolerable level (approximately  $0.5^{\circ}\text{C}$ ). It is assumed that this noise or record trace fluctuation is composed of both spatial surface temperature variations and instrument-induced noise.

Turbulence tests have been performed at various speeds and altitudes. When the sensing unit is flush-mounted over the opening and exposed to the air stream, the temperature trace is completely obscured by noise. This noise due to turbulence has been attributed to instantaneous obstruction in the operation of infrared beam chopping mechanism. This effect has been partially eliminated by raising the sensing unit and pressurizing the aircraft in order to force air out of the opening.

Acoustics, vibration, and shock have been suggested as other possible sources of interference. Two ART's were subjected to high intensity sound ranging from 3 to 50 cycles per second. One unit demonstrated output fluctuation of the order of  $0.2^{\circ}\text{C}$  at 20 cps and  $0.1^{\circ}\text{C}$  at 10 cps. The infrared chopper speed is 20 cps; the sound may create resonance at this frequency and at its harmonics.

Tests were performed using a vibration test machine at frequencies and amplitudes matching those of the aircraft. The unit was vibrated from 0 to 60 cps at 0.012- and 0.025-inch double amplitude vertical displacement. (Aircraft vibration is maximum at 30 cps and 0.0076-inch amplitude.) Fluctuations of the order of  $0.15^{\circ}\text{C}$  appeared in the trace at 20 and 60 cps.

Shock tests were performed by allowing the sensing unit to drop 0.15 to 0.25 inches onto a wooden surface--as much as  $1.0^{\circ}\text{C}$  of noise resulted. The ART is shock-mounted in the aircraft; it is unlikely that the instrument would be subjected to these force equivalents during flight.

By far, the most serious physical influence on the instrument is air turbulence.

## EXPERIMENTAL FLIGHT TESTS

Initially, aerial surveys were made to determine how well ART field measurements over an ocean area compared with the ASWEPS sea surface temperature chart, a subjective analysis of sea surface temperature observations collected by naval and commercial ships. Aerial surveys were also made to test ART reliability by observing the agreement of ART measurements repeated over a given area. More flight tests were made to compare ART readings with bucket thermometer, towed thermistor, and injection temperatures taken simultaneously from ships. On one occasion, measurements were also compared with bucket thermometer temperatures taken at ARGUS ISLAND, an oceanographic tower off

Bermuda. All told, four sets of comparative measurements were made, three over ships and one over the tower. A number of field measurements were made also to test ART reliability over areas of strong and weak surface temperature gradients.

### A. Measurement Reliability

On 18 July 1962, the ART was flown along a triangular path. Figure 1 shows the results of the temperature-distance profile comparison of ART observations and the ASWEPS sea surface temperature chart for two successive flights. Comparison of the temperature profiles indicate good agreement. Figures 2 and 3 show an example of measurement reliability of ART data taken 7-8 November 1962. In this example, a second flight was scheduled over a triangular flight path 10.5 hours after the first. A section of the analog recording has been reproduced from both flights over a portion of the route where the flight tracks were identical. An inspection of both traces shows excellent agreement and presents evidence of the instrument's ability to reproduce field measurements.

### B. Measurement Accuracy

On 25-26 January 1963, the USCGC CASCO made measurements of sea surface temperature between Boston and Ocean Weather Station ECHO. The area between Boston and the Gulf Stream contains strong surface temperature gradients. Continuous measurements



COMPARISON OF 2-HOUR TEMPERATURE CHANGES, 18 JULY 1962 WITH SYNOPTIC ANALYSIS

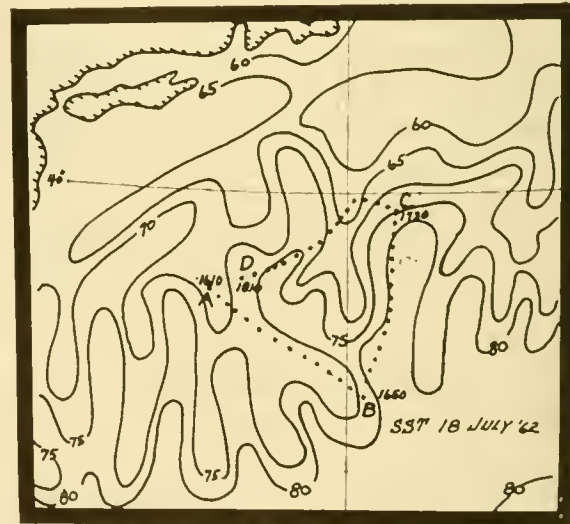

SYNOPTIC ANALYSIS OF SEA SURFACE TEMPERATURES SHOWING ART FLIGHT TRACK

Figure 1. Synoptic analysis of sea surface temperatures in comparison with IRT flight records, July 18, 1962

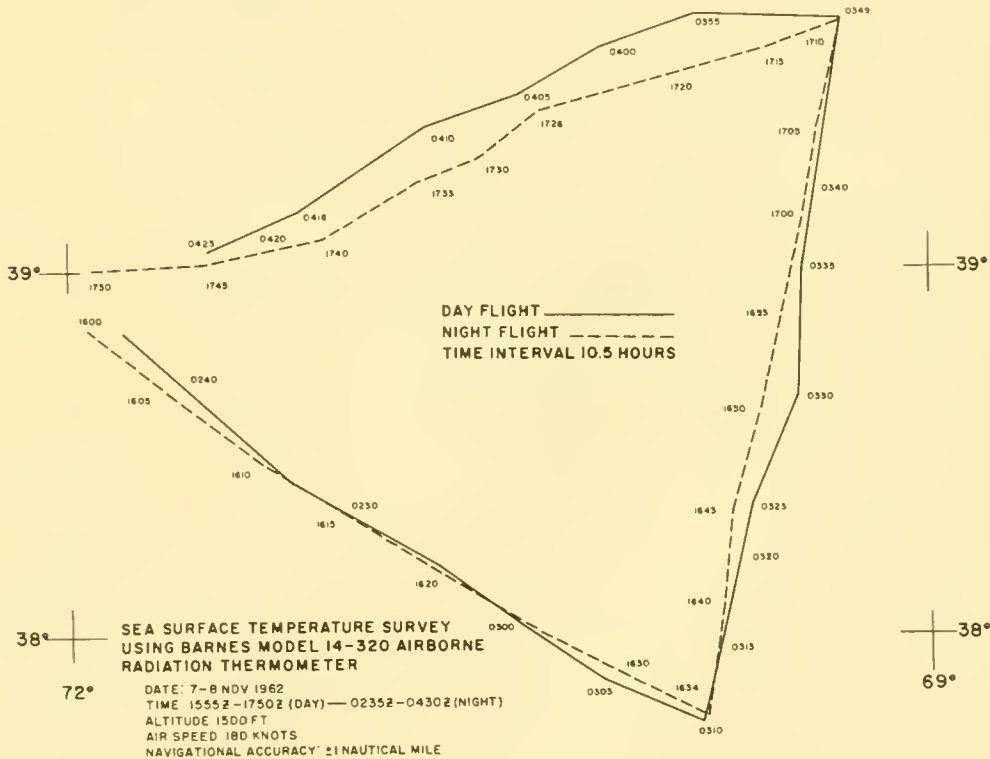
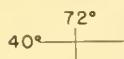
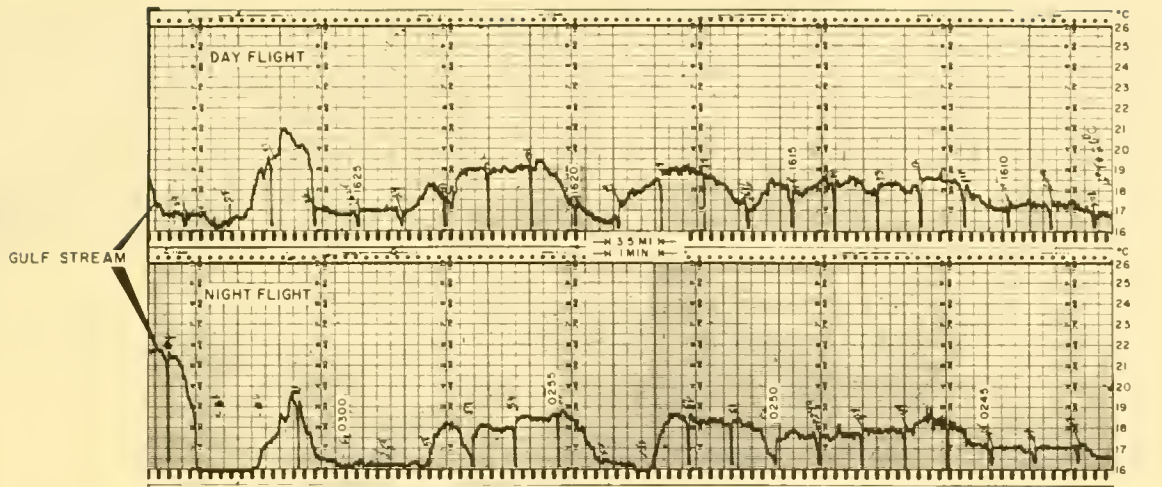
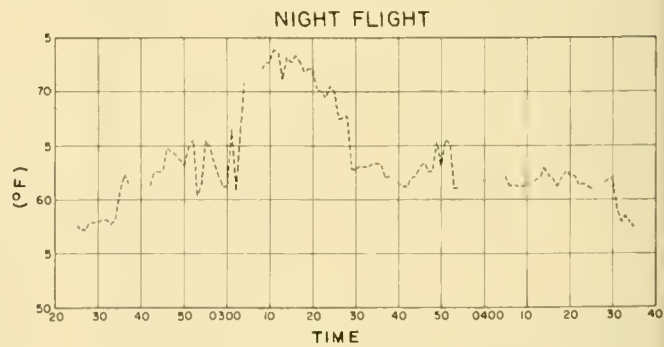
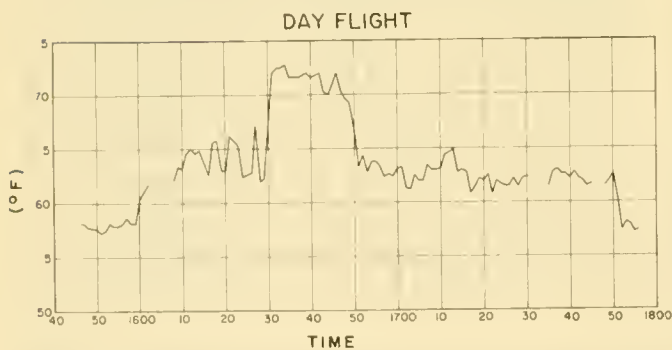
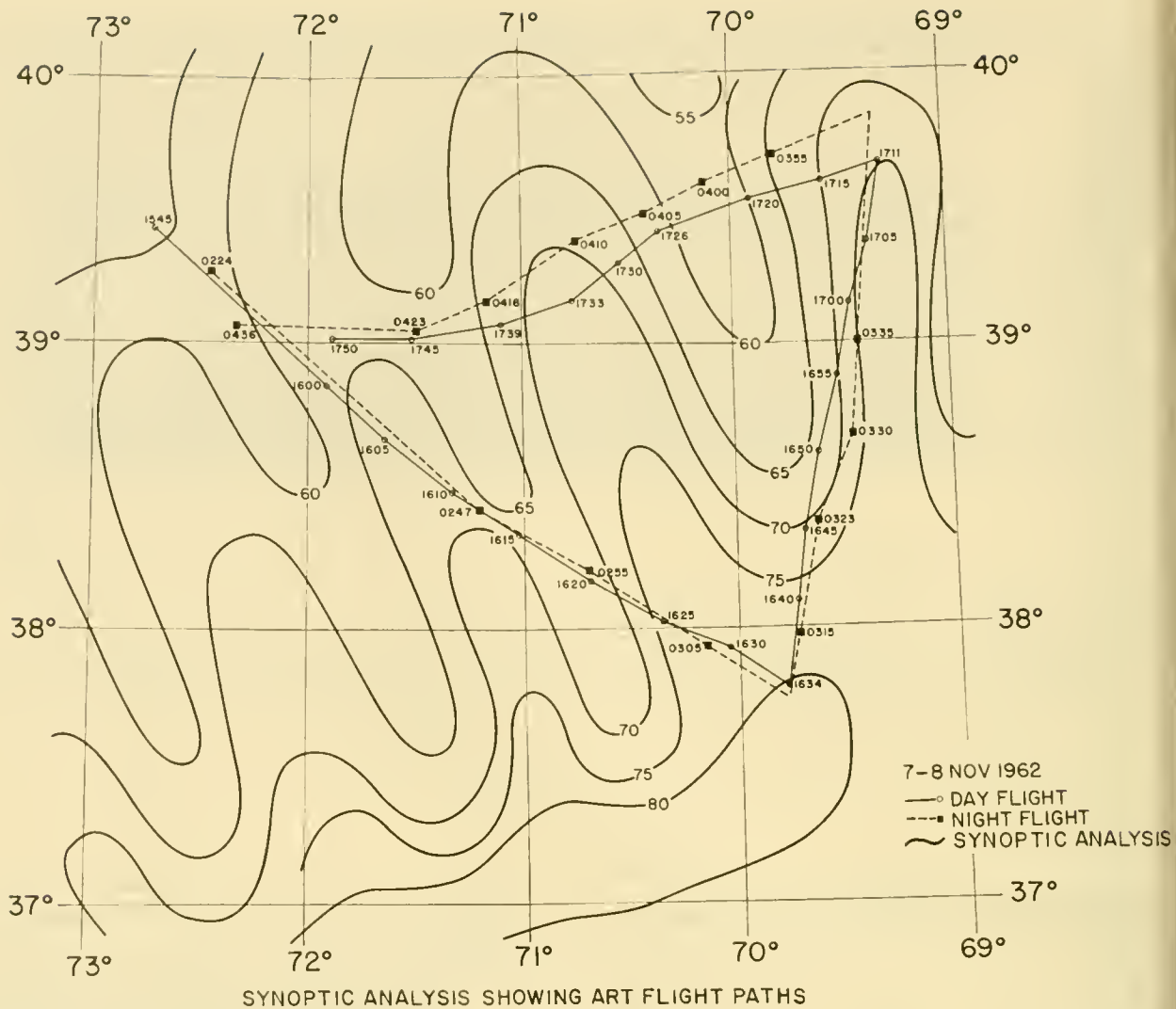

Figure 2. Day and night comparison of IRT sea surface temperature record, November 7-8, 1962



SURFACE TEMPERATURE PROFILES OVER FLIGHT PATHS

Figure 3. Synoptic analysis of sea surface temperatures in relation to day and night IRT records, November 7-8, 1962



were made with a towed temperature probe located 100 feet below the surface. Hourly injection temperatures were also recorded. A flight was made along the ship's track on 26 January. After overtaking the CASCO, the aircraft flew at various altitudes over the ship while simultaneous measurements were made from the ship with a Barnes model IT-1 infrared thermometer (IRT). The meteorological and oceanographic conditions during these flights are shown in table 1. The temperature-distance profiles for probe and ART measurements are shown in Figure 4.

Table 1. Meteorological and oceanographic conditions for comparative study with CASCO

Surface air temperature	- 49°
Sea surface temperature	- 68°
Relative humidity	- 60-96%
Wind speed	- 10 knots
Wave height	- 1-2 feet
Cloud cover	- 10/10
Ceiling	- 1,100-1,600 feet
Visibility	- 10-15 miles

Table 2. The results of simultaneous ART measurements with the shipboard infrared thermometer

<u>Alt.</u>	<u>ART</u>	<u>IRT</u>	<u>Correction for Water Vapor</u>	<u>IRT-ART Difference</u>	<u>IRT-ART Diff + Corr</u>
400'	63.4	70.0	-.5	6.6	6.1
600'	63.3	70.0	-.7	6.7	6.0
800'	63.1	70.0	-.9	6.9	6.0
1,000'	63.1	69.5	-1.1	6.4	5.3
1,200'	63.0	70.0	-1.4	7.0	5.6
1,400'	62.4	70.0	-1.6	7.6	6.0
1,200'	63.0	69.5	-1.4	6.5	5.1
1,000'	63.0	70.0	-1.1	7.0	5.9
800'	63.0	69.5	-.9	6.5	5.6
600'	62.4	68.5	-.7	6.1	5.4
400'	62.6	68.5	-.5	5.9	5.4



The comparisons show a rather good agreement over a 35°F temperature range. The gradients detected by the trailing probe and the ART were nearly identical; however, the ART values were about 7°F lower than those of the probe. This difference was also recorded during individual flights over the ship. After correction for water vapor, the ART measurements were found to be about 6°F lower than measurements made at the surface. This inexplicable difference is the largest observed during comparison tests and suggests that environmental influence showed a pronounced effect on infrared measurements during winter.

The correction for water vapor in the air column was approximated with the equation:

$$t_E = (t_a - t_s) (1 - 0.8^w)$$

$t_E$  = temperature error of the instrument

$t_a$  = mean temperature of the air column

$t_s$  = surface water temperature

w = optical thickness (measurement of water vapor in the air column)

0.8 = mean value of transmission coefficients for wavelengths between 8 and 13 microns

Another example of comparative measurements is shown in figure 5. The area between Bermuda and the Gulf Stream contains relatively weak horizontal surface temperature gradients. The USNS DAVIS recorded sea surface temperatures with bucket thermometers between Norfolk and Bermuda. A flight over a portion of the route was made on 10 March 1963. The DAVIS transited the area between 11 and 14 March. The temperature-distance profiles show good agreement, considering the time and space separation between the two samplings. The features were reproduced well, and the trend was indicated in most cases. In areas where comparison was possible, the temperature range was only about 3°F. Meteorological and oceanographic conditions over the flight track on 10 March are listed below:

Wind speed	12-30 knots
Wave height	4-8 feet
Air temperature (flight level)	60°-68°F
Rel. humidity (flight level)	70-80%

On 28 March 1963, flights were made over ARGUS ISLAND to compare ART readings to bucket thermometer temperatures taken as the aircraft passed overhead. The aircraft flew at various altitudes over the tower during a 3-hour period. The results are shown in figure 6. Differences between thermometer and ART readings generally increased as altitude

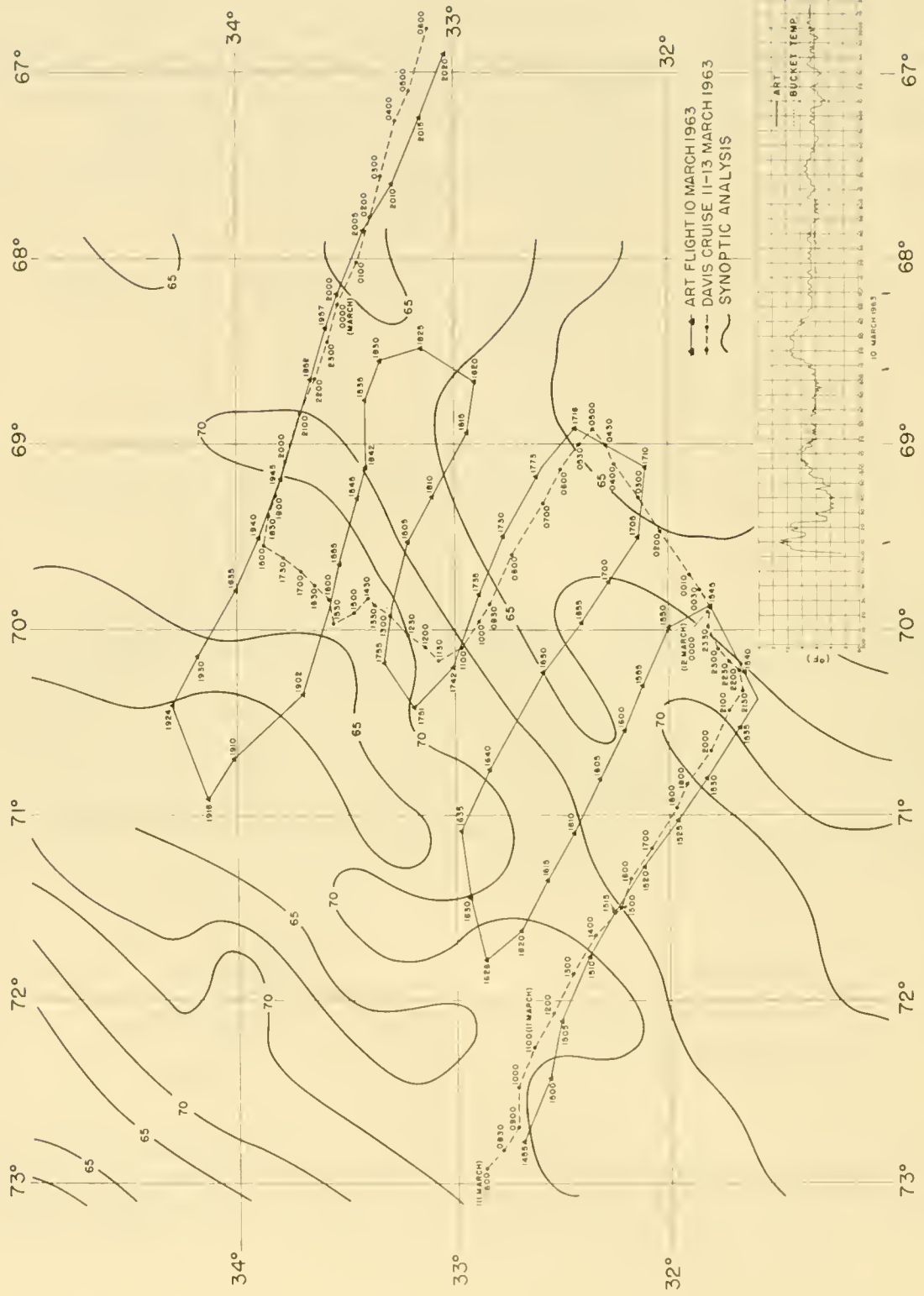

Figure 5. Synoptic analysis of sea surface temperatures in comparison with IRT flight records, March 11-13, 1963



FLIGHT TEST

28 MARCH 1963

$$\Delta t_i = (t_0 - t_w) [1 - (0.8)^w]$$

TEMP. CORRECTION  
FOR WATER VAPOR

BUCKET-ART

BUCKET THERM. (°F)

ART (°F)

ALTITUDE (FT)

200	66.0	66.2	+2	-01
400	65.9	66.2	+3	-02
600	65.7	66.2	+5	-02
800	65.5	66.2	+7	-03
1000	65.5	66.3	+8	-02
1200	65.7	66.3	+6	-02
1400	65.7	66.2	+5	-05
1600	64.8	66.2	+1.4	-04
1400	65.5	66.3	+8	-06
1200	65.5	66.3	+9	-04
1000	66.0	66.3	+3	-02
800	66.0	66.5	+5	-01
600	65.5	66.5	+1.0	-03
400	66.4	66.6	+2	-02
200	65.5	66.6	+1.1	-01

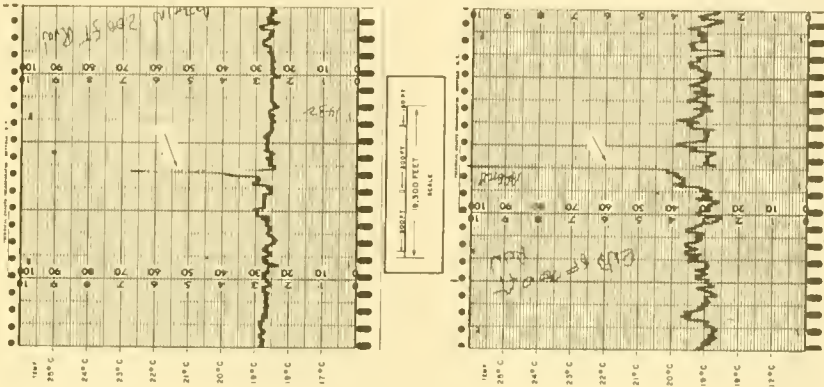

Figure 6. Comparison of ART temperatures from various altitudes and bucket temperatures at Argus Island, March 28, 1963

increased. It should be noted that differences of less than about  $0.4^{\circ}\text{F}$  are within the accuracy limits of instrument calibration. The meteorological and oceanographic conditions during these tests are shown below:

Wind speed	10-12 knots
Wave height	2-4 feet
Air temperature (surface)	$66^{\circ}$ - $67^{\circ}\text{F}$
Rel. humidity	85-90%
Cloud cover	2/10

In evaluation of these comparisons, ART temperatures are at best only approximations of the temperature of the water at the base of the tower. Although the ART temperatures at the base of the tower are fixed precisely by the edge of the thermal signature of the tower, they represent the temperature of sea surface over at least 150 feet as shown by the equivalent distance scale for two examples in figure 6. The width of the recorded trace corresponds to a distance of about 150 feet along the flight path of the aircraft at a recording speed of 2 inches of chart per minute.

On 20 and 21 November 1963, measurements of sea surface temperatures were made over shallow water south of New Providence Island in the Bahamas. As the aircraft passed overhead, surface temperatures were recorded by a ship with bucket and reversing thermometers and with a continually recording towed temperature probe. Twenty passes were made over the ship at an altitude of 100 feet followed by ten passes at 1,500 feet. The differences between the ART and the three shipboard measurements, as well as mean differences for each group of data, are shown in tables 3 and 4.

The ART readings at 100 feet compared most favorably with bucket and reversing thermometer measurements and showed a net drop of temperature when altitude was increased to 1,500 feet. The average difference between the ART and the three shipboard measuring devices,  $-0.30^{\circ}\text{F}$  at 100 feet, is within the accuracy limits of instrument calibration. However, the average difference between the ART and three shipboard devices at 1,500 feet was about  $-1.0^{\circ}\text{F}$ . The correction for water vapor using the previously introduced expression was about  $+0.04^{\circ}\text{F}$  for 100 feet of altitude and about  $+0.4^{\circ}\text{F}$  for 1,500 feet.

During these tests, surface temperature varied between  $76^{\circ}$  and  $78.5^{\circ}\text{F}$ , and relative humidity was about 75 percent. Winds were light, waves ranged from 2 to 3 feet, and cloud cover was about 1/10.

Unlike the tower, the ship gave no thermal signature on the ART recording. This made selection of corresponding temperatures for comparison less precise. Figure 7 shows two examples of the ART recordings with signals indicating when the aircraft was directly overhead from observers, both in the aircraft and aboard ship. These observations are separated in

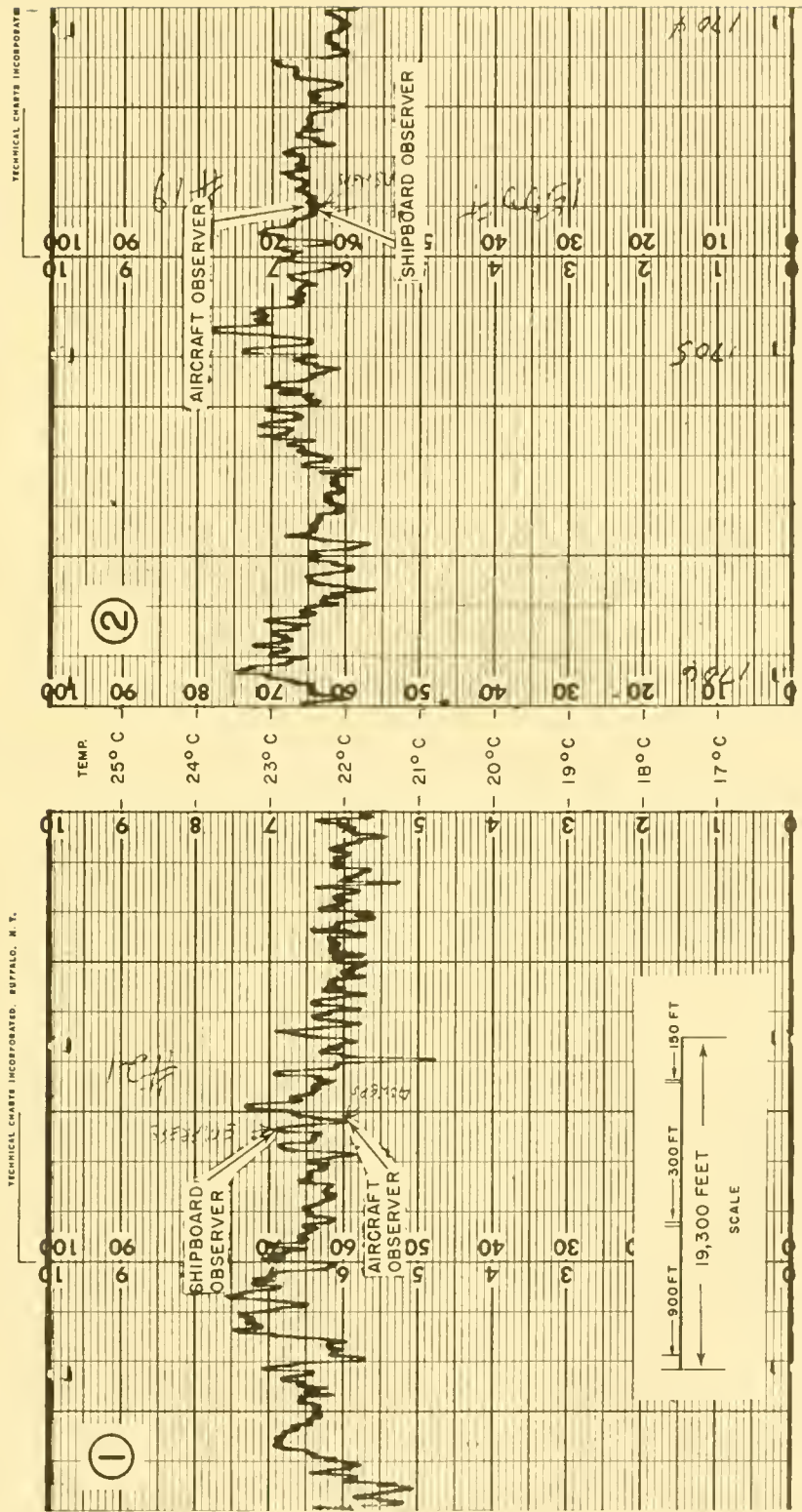

Figure 7. Comparison of ART and shipboard temperatures, November 20 and 21, 1963

Table 3. Repeat observations of water temperature on November 20-21 1963, 100-foot series

Altitude (ft.)	(°F)									
	ART	Bucket	Thermistor	Reversing	ART-B'kt	ART-Therm	ART-Rev	B'kt-Therm	B'kt-Rev	
100	77.9	78.1	78.3	78.3	-2	-4	-4	-2	-2	
100	77.9	78.1	78.3		-2	-4		-2	-2	
100	77.8	78.3	78.4	78.3	+5	+4	+5	-1	0.0	
100	77.7	78.1	78.4		-4	-7		-3		
100	77.9	78.1	78.6	78.3	-2	-7	-4	-5	-2	
100	78.8	78.4	78.6		+4	+2		-2		
100	77.4	78.1	78.6	78.3	-7	-1.2	+9	-5	-2	
100	77.7	78.1	78.6		-4	-9		-5		
100	77.4	77.2	76.8		+2	+6		+4		
100	77.0	75.9	76.8		+1.1	+2		-9		
100	75.7	75.6	76.1		+1	-4		-5		
100	73.9	72.9	73.8	73.6	+1.0	+1	+3	-9	-7	
100	72.7	72.9	73.8		-2	-1.1		-9		
100	72.7	72.9	73.8		-2	-1.1		-9		
100	72.3	73.6	75.0		-3	-2.7		-1.4		
100	73.8	73.6	74.5		+2	-7		-9		
100	72.9	73.8	74.5		-9	-1.6		-7		
100	72.9	73.8	74.5	73.8	-9	-1.6	-9	-7	0.0	
100	73.9	73.8	74.5		+1	-6		-7		
100	73.9	73.8	74.5	73.6	+1	-6	+3	-7	+2	
Mean Differences					-.04°F	-.66°F	-.21°F	-.56°F		-.17°F



Table 4. Repeat observations of water temperature on November 20-21 1963, 1500-foot series

Altitude (ft.)	(°F)									
	ART	Bucket	Thermistor	Reversing	ART-B'kt	ART-Therm	ART-Rev	B'kt-Therm	B'kt-Rev	
1,500	71.8	73.2	73.7	73.2	-1.4	-0.9	-1.4	+0.5	0.0	
1,500	71.4	73.2	72.7		-1.8	-1.3		+0.5		
1,500	71.4	73.2	72.7	73.2	-1.8	-1.3	-1.8	+0.5	0.0	
1,500	71.4	73.2	72.5		-1.8	-1.1		+0.7		
1,500	71.6	73.2	72.7	73.2	-1.6	-1.1	-1.6	+0.5	0.0	
1,500	71.4	73.2	72.5		-1.1	-1.1		+0.7		
1,500	73.2	73.2	72.5	73.4	0.0	+0.7	+0.2	+0.7	-0.1	
1,500	72.7	73.2	72.5		-0.5	+0.2		+0.7		
1,500	72.3	73.2	72.5	73.4	-0.9	-0.2	-1.1	+0.7	-0.2	
1,500	71.8	73.2	72.5		<u>-1.4</u>	<u>-0.7</u>		<u>+0.7</u>		
Mean Differences					-1.30°F	-.68°F	-1.14°F	+0.62		-0.06

time as much as one second or more. In example 1 of figure 7, this time interval corresponds to about 500 feet along the flight path at a time when the recorded temperature was changing about  $1.5^{\circ}\text{F}$ . As with the test measurements made at ARGUS ISLAND, these results are at best only approximations. More exact comparisons are possible only if much faster chart speeds are used and if thermal signatures from the ship or tower are recorded.

Examples of gradients observed by the ART are shown in figure 8 through 12. Figure 8 shows synoptic data collected during an 8-hour survey over the Tongue of the Ocean and Exuma Sound on 9 February 1963. Temperatures were averaged over 1-minute intervals corresponding to distances of about 3.5 miles. Figure 9 shows a proposed analysis of the data indicating generally strongest sea surface temperature gradients along the edges of the Tongue and the Sound.

A further example of temperature gradients observed by the ART is shown in figures 10 and 11. Figure 10 shows the flight tracks in an area southeast of the Gulf Stream covered by four flights between 8 and 11 April 1963. The proposed analysis of the data collected during these flights is shown in figure 11. Sea surface temperature gradients along the track exceeded  $0.3^{\circ}\text{F}$  per mile at several locations.

The last example of gradient detection by ART is shown in figure 12. The gradient at the edge of the Gulf Stream was about  $10^{\circ}\text{F}$  per mile.



Figure 8. Data and flight tracks from ART flight of February 9, 1963, Tongue of the Ocean and Exuma Sound



Figure 9. Isotherm analysis of data of figure 8



FIGURE 23

FLIGHT TRACKS OF SEA SURFACE  
TEMPERATURE AERIAL SURVEY—  
8-11 APRIL 1963

T A T E S

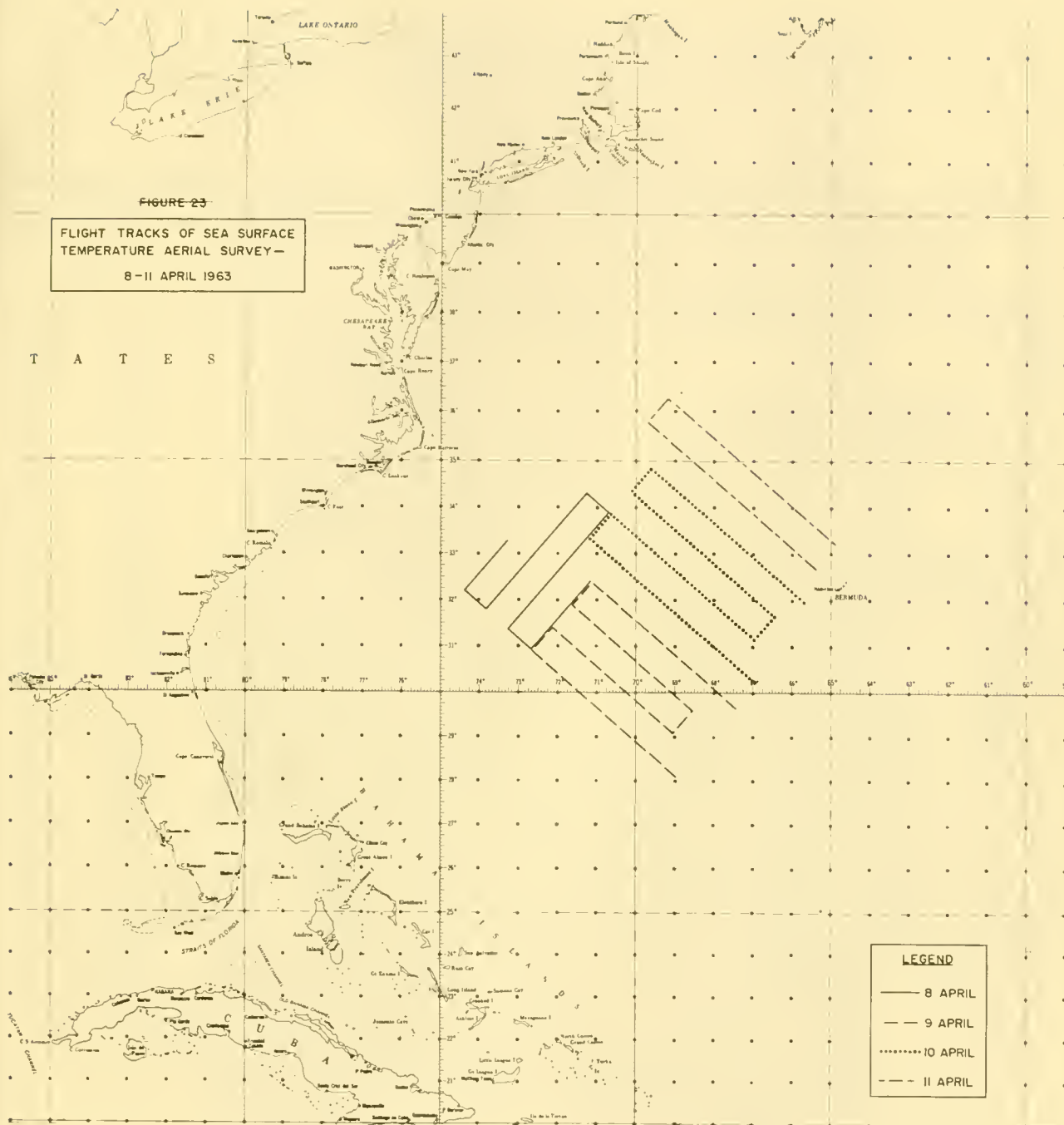

Figure 10. Area southeast of Gulf Stream covered between  
April 8 and 11, 1963

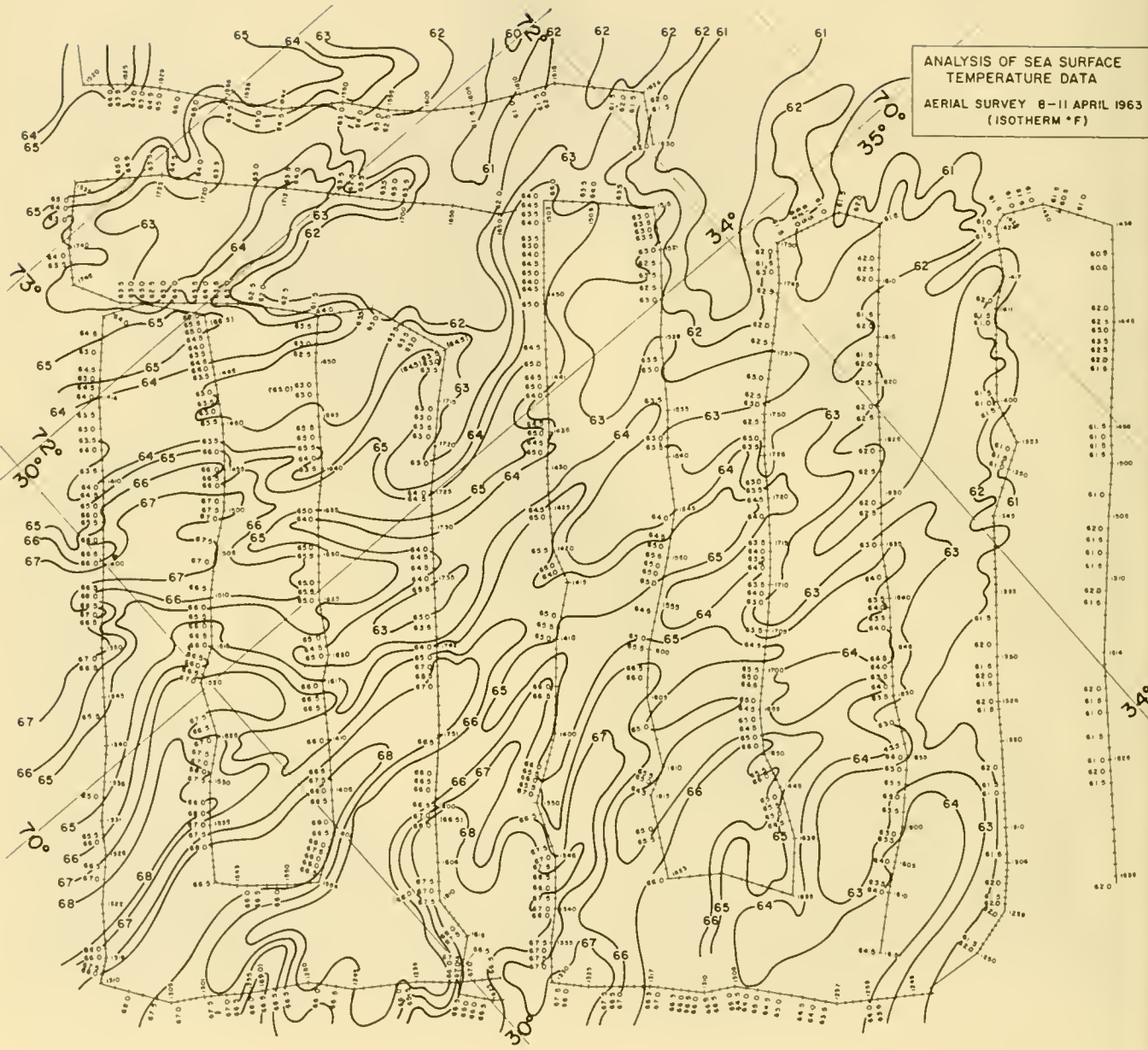

Figure 11. Analysis of data collected from ART flight of April 8 and 11, 1963

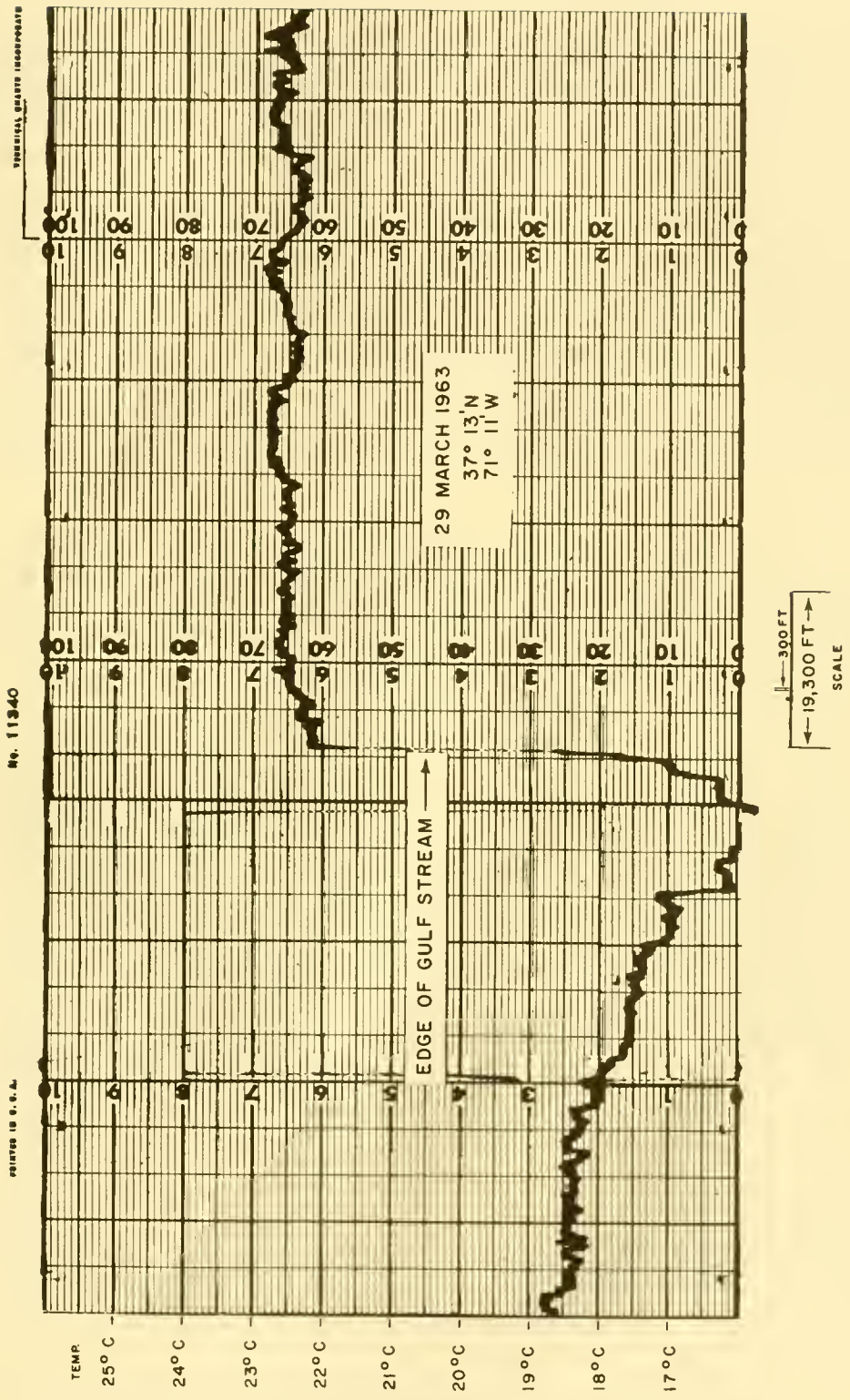

Figure 12. ART record showing Gulf Stream edge as recorded on flight of March 29, 1963

# USE OF RADIATION THERMOMETER DATA IN SYNOPTIC OCEANOGRAPHIC ANALYSIS AND LAYER DEPTH ESTIMATION

Synoptic sea surface temperature charts based largely on injection temperature reports from commercial ships and surface temperature readings from bathythermograph observations taken by Fleet, Coast Guard, and research ships are prepared regularly at the Naval Oceanographic Office for dissemination to Fleet units.

Although more than 450 daily ship reports of sea surface temperature and 60 bathythermograph observations are available for preparation of regional analyses, data are seldom sufficient to permit realistic portrayals of temperature patterns. (The technique of sea surface temperature analysis is presented in detail in the U. S. Naval Oceanographic Office Technical Report 70, "Sea Surface Temperature Analysis," by Blair Gibson.) Therefore, data are grouped into 5-day periods and analyzed on an overlapping basis three times each week. Figure 13 shows the typical ratio between daily and 5-day collections of surface reports. Empirical relationships between the sea surface temperature field and the subsurface temperature structure can be used in many cases for estimating layer depths.

Since density of surface temperature reports is a major problem in many areas, ART measurements along tracks tailored to the specific requirements of regional analysis are of considerable value. Although aerial survey provides collection of data along tracks up to

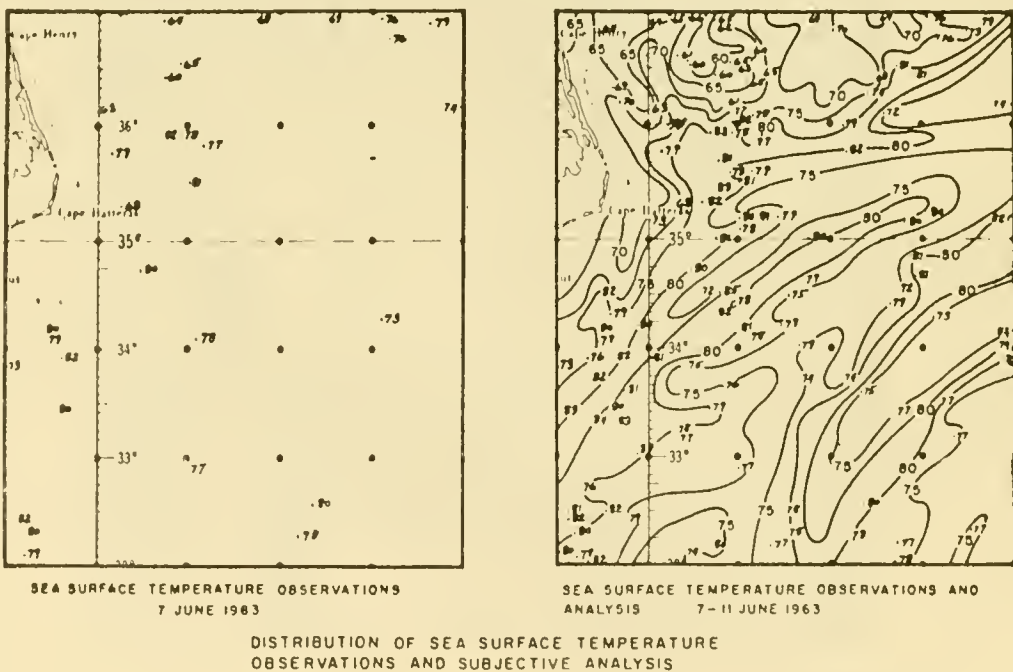

Figure 13. Example showing the ratio between daily and five-day collecting of surface reports



several thousand miles in length in a single day, the data are not sufficient for preparation of a regional chart such as the one shown in figure 14. Most of the ART data collected to date have been used to supplement shipboard reports and other data sources. Sea surface temperature patterns recorded by aerial survey have been used for analysis of data included in regional charts. Over large areas where data are sparse and maximum coverage is desired, a straight-line flight path also has been used. By flying perpendicular to major currents in an area, positions of water masses can be checked for realignment of isotherms in correcting sea surface temperature patterns. Straight-line flights of this type repeated on successive days and spaced 30 to 60 miles apart have been planned often to cover an area progressively.

More detailed coverage within short time periods is required for support of some Fleet exercises and research projects. In such instances, a grid flight pattern is more effective than the single straight-line track. The grid pattern is a series of flight tracks spaced from 15 to 60 miles apart so as to produce maximum coverage of the given area. Such grid patterns also can be flown on successive days to determine micromovement of surface temperature patterns. The area covered by such a grid is necessarily small, but the temperature field can be completely surveyed.

#### SUMMARY

Sea surface temperatures measured with the Barnes model 14-320 ART are subject to environmental influences at the air-sea interface and at the aircraft. The instrument responds to acoustic vibration, shock, and turbulent air flow at or near the sensing unit. Noise produced by these factors degrade measurement accuracy; however, such interference can be reduced by proper mounting of the instrument in the aircraft.

Comparison of the ART with standard surface temperature measuring methods suggest that atmospheric conditions and the environment at the air-sea interface can have a pronounced effect on the accuracy of the airborne radiation measurements. At low altitudes in fair weather over a well mixed sea, infrared measurements of the sea surface have agreed (about  $\pm 0.4^{\circ}\text{F}$ ) with standard measurements within the limits of accuracy of the system. At other times, airborne infrared measurements have been  $7^{\circ}\text{F}$  lower than standard measurements. Although biased by these outside influences, airborne radiation thermometry data reflect surface gradients well. The primary value of aerial survey at this time appears to lie in determination of gradient zones, rather than absolute temperatures.

# USE OF THE INFRARED THERMOMETER IN ROUTINE COASTAL SURVEY -- A SUMMARY

by John R. Clark and Richard B. Stone, Sandy Hook Marine Laboratory,  
Highlands, New Jersey

## INTRODUCTION

The Sandy Hook Marine Laboratory has used the Barnes infrared thermometer (IRT) in coastal sea surface temperature surveys since the summer of 1962. In December 1962 a series of monthly surveys of the surface waters of the Continental Shelf off New York and New Jersey was initiated. The program was expanded in January 1964 to include the area from the eastern tip of Long Island to Nantucket Shoals. Our IRT sea temperature survey is designed to provide near-simultaneous observations of temperature and water movements over an area of 16,000 square miles. (See Figure 1) This program has provided a special kind of experience of value to the Workshop because of its regular repetitive nature. The program has been briefly mentioned and the features of the instrument discussed previously by Clark and Frank (1963).

Aircraft for the survey are furnished by the U. S. Coast Guard Air Stations, Brooklyn, N. Y. and Salem, Mass. The standard Coast Guard search and rescue craft, the Grumman UF2G ("Albatross") has proved ideal for this work. The survey is made in flights of about five hours each, on consecutive days if possible, to provide near-synoptic coverage along the 1800 miles of flight track.

The IRT is utilized to record a single parameter of the environment, surface temperature, over large areas in a short time. The data are utilized in ecological studies; specifically, to help explain the influence of temperature on the distribution of migratory fishes and upon seasonal cycles of ocean productivity. However, the IRT measures only the "micro-surface" (the upper 0.1 mm) and can be considered only an indicator of the near-surface layer temperature. The program requires that near-surface temperature be estimated to  $\pm 2.0^{\circ}\text{F}$ .; this is possible if the micro-surface temperature can be measured to  $\pm 1.0^{\circ}\text{F}$ .

Conventional shipboard temperature measurements, by bucket and immersion thermometer, normally refer to the upper meter but also provide a biological useful index of temperature for the whole mixed layer in the relatively shallow waters of the Continental Shelf. Our goal could be defined most simply as an attempt to estimate "bucket-depth temperature" with a maximum error of  $\pm 2^{\circ}\text{F}$ . It now appears that under some circumstances this goal can be reached easily but under others only with some difficulty.

The greatest problem has been correcting for the difference between temperatures of the micro-surface and temperatures of the immediate subsurface, the conventional "surface temperature" or bucket temperature. We could find no data in the literature which could be used to estimate bucket temperatures from micro-surface temperatures under varying environment conditions. Until such data are obtained it will be difficult to estimate bucket temperatures to closer than  $\pm 3^{\circ}\text{F}$ .

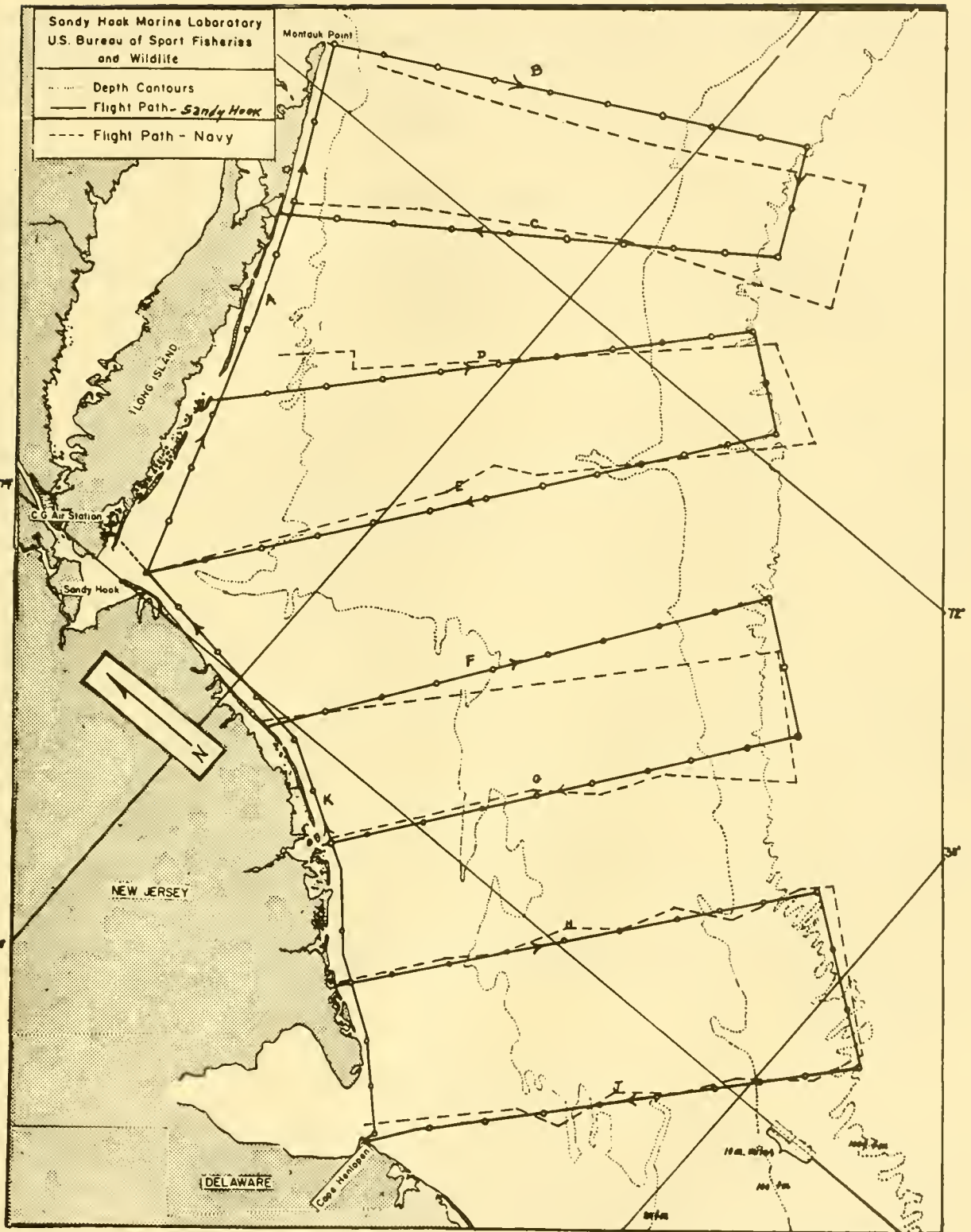

Figure 1. Flight tracks of UF2G (Sandy Hook Marine Laboratory - Barnes IT-1) and Constellation (Navy - Barnes 14-320 ART) for comparative survey operation



Other problems of consequence have been associated mostly with power sources, chart recorder, and the instrument itself. Errors caused by atmospheric radiation of infrared are considered to be of little consequence because of precautions used in the survey procedure. Water vapor in the air path undoubtedly contributes some error to the readings, but in flying at low altitude (500 ft.) this is minimized.

### INSTRUMENT PROBLEMS

Our experience has been primarily with the Barnes IT-1, operated from a basic power source of 21-24 VDC (from two 12-volt storage batteries) and 27-28 VDC (from the aircraft auxiliary power unit) through an ATR No. 28 URSF 115 VAC inverter. A NESCO JY 110-2 single-channel recorder was used. The three units were mounted in a portable rack for convenience.

Troubles with the inexpensive ATR inverter arose from variations in frequency output associated with variation in voltage input; e.g., 21 VDC yielded 59.9 c.p.s. and 28 VDC 61.1 c.p. A difference of about 1 c.p.s. in the power input to the IT-1 produced a difference of about 3°F. in the temperature readout. This effect can be corrected by instrument calibration (gain adjustment) if the inverter input voltage is known or through use of a known temperature reference target. A better solution is to use a frequency controlled power source.

The most severe problems with the instrument itself appeared to be related to the battery-supplied bias voltage circuit. In the IT-1 the bias voltage is supplied by 4 standard radio B batteries. With use, the decreasing voltage output of the batteries, initially 178 V, has the effect of causing a decrease in readout values. This has been corrected by gain adjustment. However, this calibration procedure is rather awkward, particularly since the batteries appear to recharge between periods of use and then decline rapidly on reuse.

In our work this problem has given rise to a possible error of about 2°F. However, the record can be corrected for this effect if frequent in-flight calibration checks are made. With the IT-1 we now make these checks routinely; every 12-15 minutes when possible. The reference target is a container of water maintained within the range of sea surface temperature prevailing during that time (ice chips are carried aboard). The necessity for these precautions should be obviated by changes made in subsequent models which have electronic-bias voltage supply.

### WEATHER PROBLEMS

In the IT-1 thermometer, radiation from the atmosphere per se is nearly eliminated by the optical system which received radiation only in the 8 to 13 micron range. Thus dry air should offer no interference to measurement of sea surface temperature with the IT-1. However, radiation or attenuation from water vapor in the atmosphere can interfere. But, we have not detected significant effects from water vapor in our surveys even at high relative humidities. Condensed vapor has been a problem, however, in the form of medium to heavy fog, rain, or snow and we have avoided flying in these conditions or have rejected such data



as have resulted therefrom. However, fog patches and light rain appeared not to affect our readings significantly under the sea and air temperature conditions encountered.

### FACTORS AFFECTING SURFACE TEMPERATURE DETERMINATION

Temperature measurement of the micro-surface of the sea with temperature-calibrated infrared detectors is a well established technique. Doubts about the accuracy of the infrared thermometer for this purpose are related to an apparent confusion over exactly what is being measured at the sea/air surface. Since our objective is primarily to estimate the temperature of the upper meter of the sea, our concern is with our ability to make these estimates. We have collected data which bear on the accuracy of the estimating procedure.

A repeatability test consisting of a two-aircraft simultaneous comparison was carried out as a cooperative venture between the Sandy Hook Marine Laboratory and the U. S. Naval Oceanographic Office. A special flight with our IRT (Barnes IT-1) was set up following our regular survey flight track (within an expected maximum error of  $\pm 2$  miles). This track was followed by a second aircraft, a Navy Constellation using a Barnes 14-320 # ART. The flight paths could not be made to coincide exactly because the two planes could not fly side-by-side, the minimum speed of the Constellation being 40 mph greater than that of the UF2G (See Figure 1). However, the two aircraft were close enough together for most of the operation to give useful comparisons because the area was typified by gradual change and isotherms about normal to the direction of flight.

In using the portable IT-1 with a tripod-mounted sensor head directed through the open side hatch of the UF2G aircraft, we are able to re-position the head easily for frequent calibration checks against a known reference target, (a water-bath). No corrections were required for the IT-1 on this flight as it read within our  $\pm 0.5^\circ\text{F}$ . operation limit at all times. Checks were made against lightship bucket temperatures where possible with results as shown in Table 1. That micro-surface temperature averages about  $1.0^\circ\text{F}$ . lower than bucket temperature is to be expected for the beginning of the cooling season, in early Autumn.

Table 1. Lightship and IRT Temperature Comparisons On  
Sandy Hook/Navy Comparative Flight

Date/Time	Lightship	Position	Bucket Temp. $^\circ\text{F}$ .	IT-1 Temp. $^\circ\text{F}$ .	Differ- ence $^\circ\text{F}$ .
9/30 -0900	Scotland	5 mi. E. Sandy Hook	61.0	60.5	-0.5
-1330	Scotland		61.0	61.0	0.0
-0902	Ambrose	10 mi. E. Sandy Hook	62.0	60.0	-2.0
10/1 - 0910	Barnegat	7 mi. E. Barnegat inlet	63.0	62.0	-1.0
- 1215	Delaware	25 mi. E. Cape Henlopen	63.0	62.0	-1.0

The results of the comparative flights are shown in Figures 2 and 3. The first day's flight, including transects B-E, was somewhat hampered by navigational errors and instrument problems. The second day's flight, including transects F-J, was better coordinated and provided a more controlled test. A general consistency can be seen in gradient patterns along all transects. For transects F-J, the more comparable set, the differences vary from 1° to 4°F. The average difference of about 2.5°F. lower for the Navy instrument is a matter of instrument calibration. The real variation then was  $\pm 1.5^\circ\text{F}$ ., this is 0.5° F. higher than the nominal accuracy level of  $\pm 1.0^\circ\text{F}$ . required to meet our program objectives. In order to reach the higher level of accuracy required, a completely new instrument ensemble will be utilized; power supply, recorder, and IRT will all be replaced with improved equipment.

It is apparent that subsurface temperatures can be estimated from IRT surface readings if all significant parameters of variation are known and their effects precisely determined. There is at hand neither the theory nor the empirical data with which to do this. However, the major effect appears to be produced by the annual cycle of solar radiation. This is demonstrated in Table 2 where we have listed micro-surface/bucket-depth temperature difference for a series of monthly flights extending over one year, all of which were made in daylight hours between 8:30 A.M. and 4:00 P.M. The micro-surface tends to be cooler than the immediate subsurface in Autumn and Winter, nearly the same in Spring, and apparently somewhat warmer in the Summer. The "average" condition is for the micro-surface to be about 1.0°F. cooler than the immediate subsurface. The data are plotted in Figure 4.

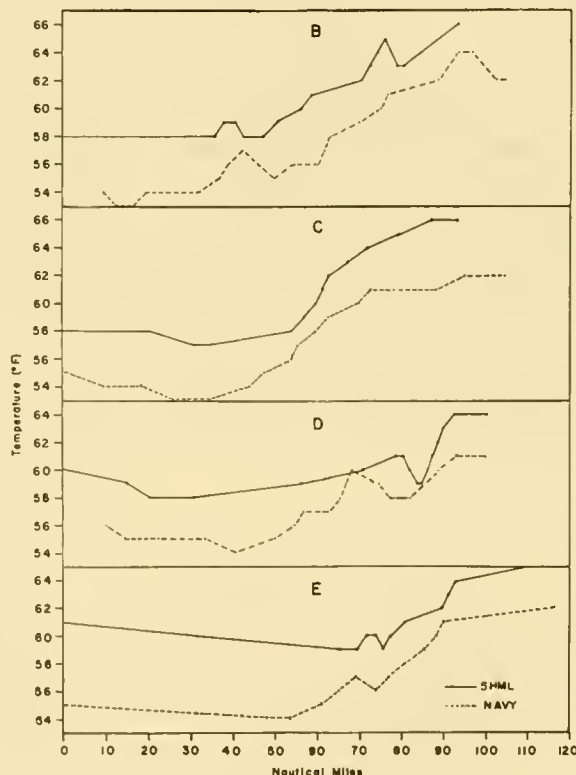

Figure 2. Temperatures from Sandy Hook - Navy comparative flight for transects B-E, September 30, 1963

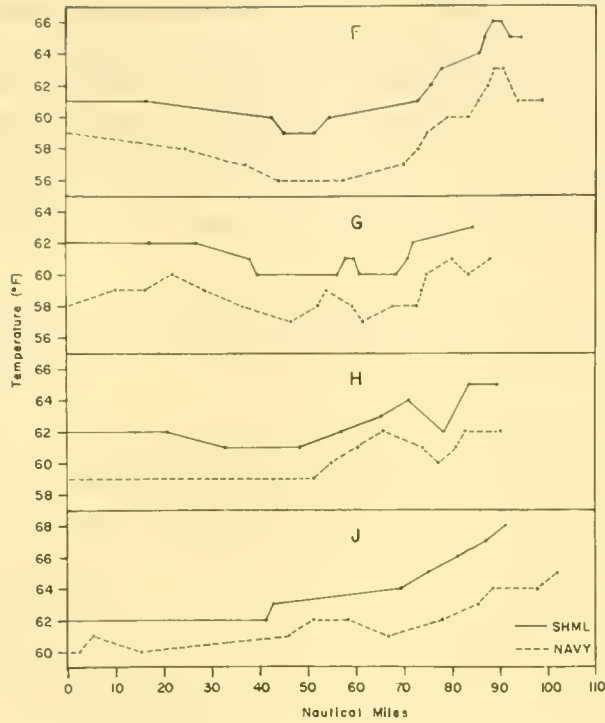

Figure 3. Temperatures from Sandy Hook - Navy comparative flight for transects F-J, October 1, 1963

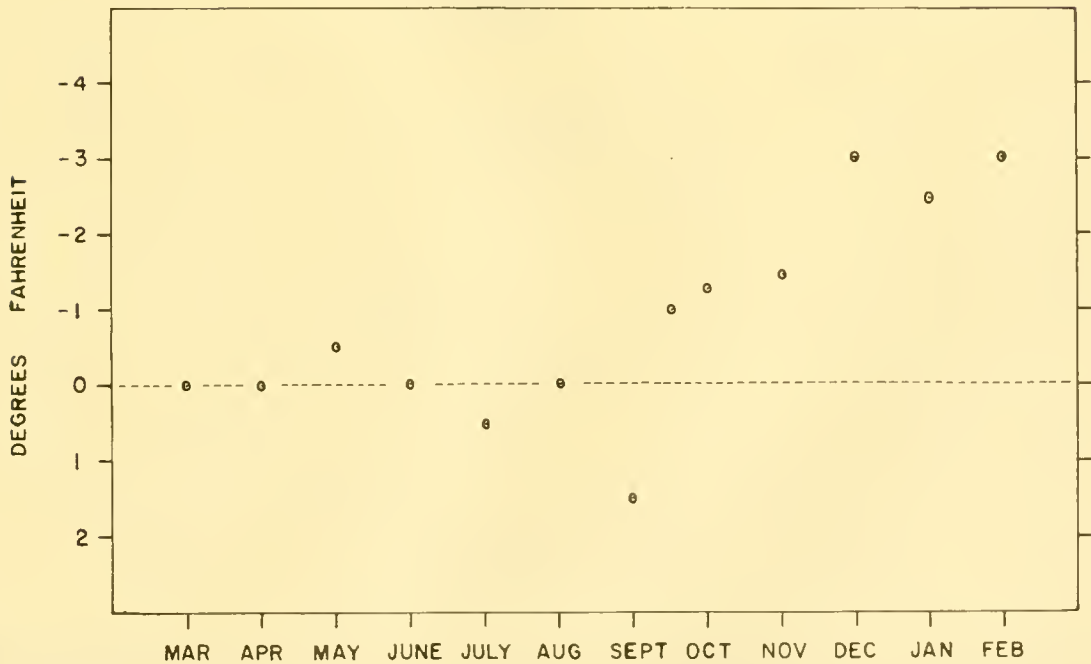

Figure 4. Differences between bucket-depth temperatures and lightship temperatures (data from Table 2)

In order to investigate further the difference between IRT recordings and subsurface temperatures a coordinated air/sea test was arranged with the U. S. Bureau of Commercial Fisheries. A transect was set up on the outer edge of the Shelf south of Block Island which would be readily accessible to both a Coast Guard UF2G aircraft from Brooklyn, New York and the Albatross IV, the research vessel of the Biological Laboratory of the Bureau of Commercial Fisheries at Woods Hole, Mass. Shipboard surface temperatures were to be recorded by the Albatross IV and IRT micro-surface temperatures by the UF2G.

The transect was approximately 30 nautical miles in length extending along the  $71^{\circ} 07'$  W meridian from latitude  $40^{\circ} 30'$  N to latitude  $39^{\circ} 59.7'$  N. Depth varied from approximately 250 feet at the northern end to more than 900 feet at the southern end of the transect.

On the morning of December 13, 1963 a rendezvous was made at the center of the transect. The Albatross IV began at the northern end of the transect at 0850 hours. From 0900 to completion at 1300, surface temperatures were recorded every 15 minutes with a Hytech recording bathythermograph. Standard B. T. casts were made at one-half hour intervals. The airborne survey began at 1115 hours. By 1155 hours the UF2G had completed two flights along the transect. Surface temperatures obtained with infrared thermometer were approximately four degrees lower than those recorded by the Albatross IV (Figure 5). The IRT recorded a temperature range of  $46^{\circ}$  to  $48^{\circ}$  F. while surface temperatures from the Albatross IV varied from  $50.4^{\circ}$  to  $52.7^{\circ}$  F.

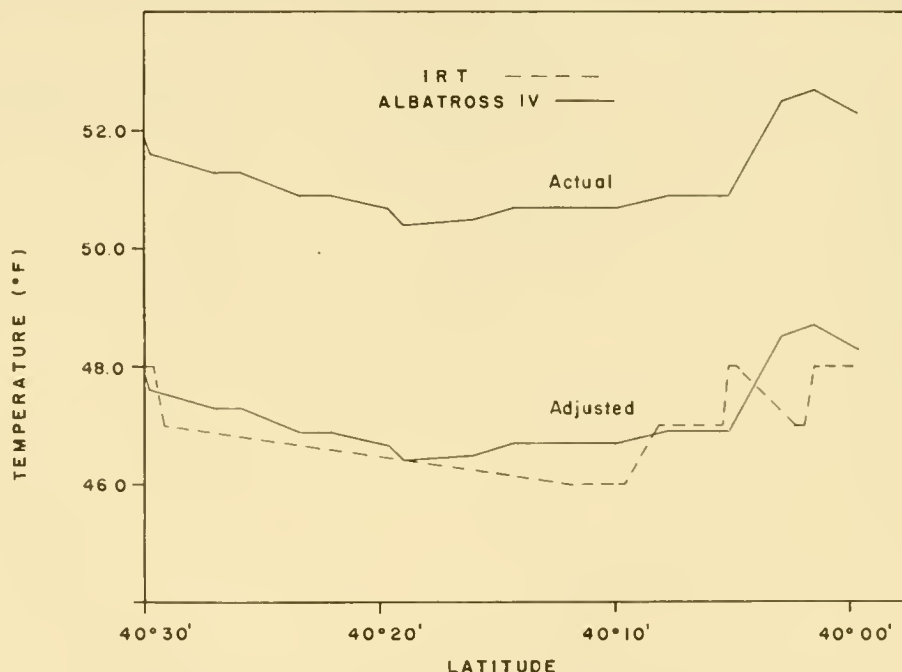

Figure 5. Surface temperature comparisons from near simultaneous records of Albatross IV and airborne IRT. Continuous recording B. T. temperatures from Albatross IV are shown as both absolute plot and superimposed on plot of IRT micro-surface readings for better comparison



Table 2. Differences between bucket-depth temperature (from lightships) and micro-surface temperature (as recorded by infrared thermometer) and supplemental data for monthly survey of the New Jersey/New York Continental Shelf as available from April 1963 to April 1964

Date	Difference micro-surface/ bucket-depth temp. °F.	Wind		Median micro- surface temp. ° F.	Median air tempera- ture ° F.
		Direction	Force (Beaufort)		
April 22, 23	0.0	SE-NW	2-5	47	49
May 21, 22	-0.5	SE	1-3	52	59
June 17, 18	-1.0 to 1.0	S-NW	2	63	73
July 15, 16	0.5	S-SW	2-4	65	78
Aug. 19, 21	0.0	SE-SW	1-3	69	73
Sept. 19, 20	1.5	SE-NW	2	67	73
Sept. 30/ Oct. 1	-1.0	Var.-NW	1-6	62	62
Oct. 21, 22	-1.0 to -1.5	SE-NW	2-5	62	62
Nov. 18, 19	-1.5	W	4-5	55	60
Dec. 16, 17	-3.0	W-NW	3-5	45	24
Jan. 27, 28/ Feb. 4	-2.0 to 3.0	W-WNW	4-6	40	41
Feb. 26, 27, and 28	-2.0 to 4.0	SW-NW	2-7	35	35
Mar. 31/ Apr. 2, 3	0.0	W-SSW	3-8	40	39

During the aerial survey the air temperature was 39°F. and the wind was NW 10 knots. From the pattern shown in Table 2 we would expect a difference under winter conditions of 2° to 4°F.

Bathythermograph records indicate the water column was relatively isothermal to 150 feet, a condition under which subsurface temperatures even deeper than the nominal bucket depth of one to three feet might be predicted from aerial IRT surveys (Figure 6).

#### REFERENCE

Clark, John R. and John L. Frank. Infrared Measurements of Sea Surface Temperatures. Undersea Technology. October, 1963

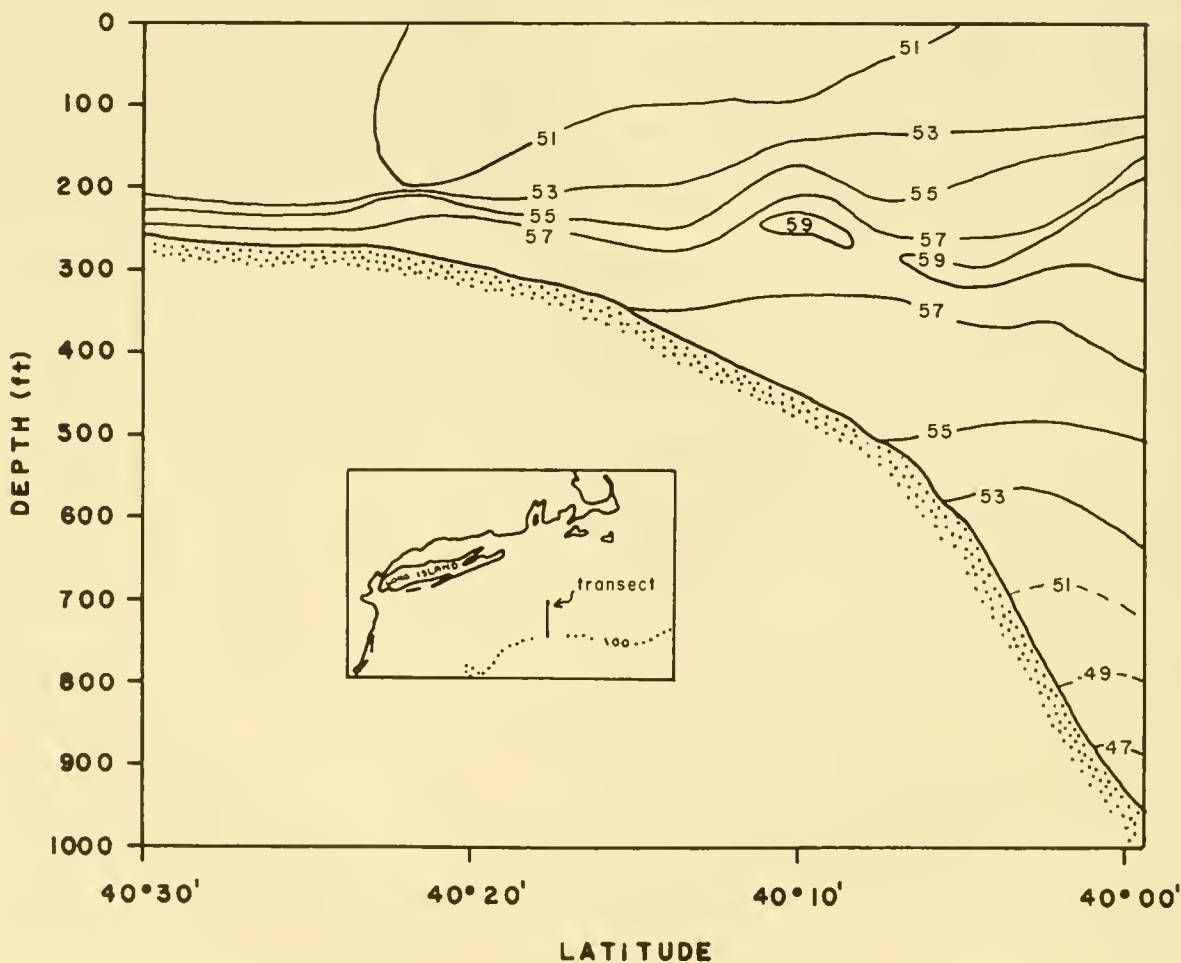

Figure 6. Temperature profile (°F.) along comparative air/sea transect (71° 07' meridian) from Albatross IV B. T. casts







MBL WHOI Library - Serials



5 WHSE 00238

